



**TIMBER
DEVELOPMENT
UK**

THE TIMBER CLADDING HANDBOOK

for specifiers, buyers and installers



Cover images (from top left):

Accoya cladding - Bradford Royal Infirmary (Accsys);

Thermally modified Frake cladding – Rossall Point Observation Tower (Howarth Timber);

Western Red Cedar cladding, residential project; Larch (coated) cladding, residential project; Siberian Larch (coated) bevel cladding – Maggies cancer support centre; ThermoWood boards, Tower Wood outdoor educational centre (ALL Silva Timber).

Publication reference:

THE TIMBER CLADDING HANDBOOK for specifiers, buyers and installers

4th edition: October 2022

Published by Timber Development UK in conjunction with
the Timber Decking & Cladding Association.

Timber Development UK (TDUK)

The Building Centre
26 Store Street
London
WC1E 7BT

Tel: 0203 198 9606

E-mail: info@timberdevelopment.uk
www.timberdevelopment.uk

Registered in England No 2515034
at the above office.

The Timber Decking & Cladding Association (TDCA)

Office 5 The Walled Garden
The Nostell Estate, Wakefield
West Yorkshire WF4 1AB

Tel: 01977 558147

E-mail: info@tdca.org.uk
www.tdca.org.uk

Registered in England No 3671430
at the above office.

The information contained in this publication is given in good faith. Every effort has been made during the consultation and publication process to ensure the guidance given is accurate.

No representation, warranty, assurance or undertaking (express or implied) is or will be made and no responsibility or liability for loss or damage – arising as a consequence of the information given – is or will be accepted by Timber Development UK, The Timber Decking & Cladding Association or any representative thereof.

© 2022 Timber Decking & Cladding Association.

All rights reserved. No part of this publication may be copied, reproduced, stored in or introduced into a retrieval system or transmitted in any form by any means, electronic, mechanical or other without the prior permission of the Timber Decking & Cladding Association (www.tdca.org.uk).

THE TIMBER CLADDING HANDBOOK

for specifiers, buyers and installers

FOREWORD

Timber cladding provides an attractive, economical and often unique way to finish and protect a building's exterior. Its versatility makes it ideal for domestic and commercial projects – refurbished and new build. Wood's natural properties bring added value too, that's in addition to its proven sustainability as a renewable building resource. It's got a lot going for it!

Correctly designed, specified and installed, timber cladding will have a long and low maintenance life. There is an abundance of information readily available to the specifier, buyer and installer of timber cladding – but depending on where you look, there is also conflicting and confusing advice out there.

This handbook aims to provide definitive guidance, as well as design inspiration, in a clear and easy to follow format with signposts to more comprehensive and trusted information should you need it. If some of the terms used are unfamiliar then the Glossary at the back of the handbook is a handy reference. The publication aligns with British Standards where applicable, making it both authoritative and consistent.

Produced in collaboration with the Timber Decking and Cladding Association, the Wood Protection Association and our educational partner Wood Campus, we hope this handbook will prove to be the 'go to' reference for all things timber cladding.



Independent, not for profit organisation that acts as a technical and advisory body for the UK timber decking and cladding industries.

www.tdca.org.uk



Not for profit trade body promoting and developing timber treatment technologies that enhance the performance and value of wood products.

www.thewpa.org.uk



A Swedish Wood initiative providing a range of information, inspiration and learning tools for DIY, architects and trade users of wood.

www.woodcampus.co.uk

Note on Fixings:

External timber cladding assemblies and their fasteners should have adequate strength and stiffness to support their own mass and the imposed wind loads. The guidance in this document is based on the assumption that peak wind loads of typical sites in the UK do not generally exceed 2.5kN/m². You may need to consult a structural engineer if the design needs to accommodate wind loads equal or greater than this or imposed loads which are deemed to be greater than average.

Western Red Cedar cladding, residential project (Silva Timber).



CONTENTS

Why Timber is a Good Choice	6
Cladding Design	8
Profiles and Arrangements	
Material Selection	10
Performance: durability, fire and movement	
Visual Grading	
Timber Gallery: characteristics and performance ratings of softwoods, hardwoods and modified wood brands	
Finishes and Coatings	
Cladding Installation	25
Storing Timber	
Build-up and Design Detail	
Metal Fixings	
Maintenance	37
UK Building Regulations and Compliance	38
Sourcing Timber	
CE Marking	
External Cladding and Fire Risk	
Checklist A summary of key points to consider	42
Sources of information including British Standard references	43
Glossary	45

WHY TIMBER IS A GOOD CHOICE

Images

Below: responsible forestry management.

Below right: harvesting operations (BSW Timber, Dalbeattie).

Page 5: Timber cladding gives a natural and homely feel to 'Maggies' cancer support centre (Silva Timber).



Wood has long been used as a structural and finishing material in construction, just look at the iconic and historic buildings around us. The appeal for wood is varied – its aesthetic qualities, natural durability, flexibility, weight to strength ratio and ease of working. Today it is even more relevant as it's one of the few building materials that can help us meet carbon zero goals due to its sustainable, renewable nature and its capability to absorb CO₂ from the atmosphere.

Timber's practical advantages

- Strong yet lightweight.
- Easily worked, can be adapted quickly to suit on-site changes or repairs.
- Comparatively economical as a building material and can be locally sourced.
- Performance and longevity of lower durability (and cheaper) timber species is easily enhanced by factory applied treatment technologies (preservative treatment or wood modification, see **Material Selection: Performance**).
- The fire performance of timber can be upgraded with approved factory applied flame retardants when deemed necessary (see **Material Selection: Performance – FIRE**).
- Surface finishes can be applied to change the appearance and give added protection (see **Material Selection: Coatings and Finishes**).
- Suitable for both new build and renovation projects.
- Timber clad buildings eliminate heavy masonry outer walls, reducing size and cost of building foundations.
- Dry installation means the external envelope is quicker to install.
- Cladding panels may be factory pre-fabricated off-site, complete with insulation and breather membrane, saving time, effort and costs.



TELL ME MORE >

Biophilic Design

- connecting with nature

Incorporating natural elements in the built environment, such as wood, water, sunlight or plants, has been proven to improve overall health and wellbeing of occupants. For example, designers of medical facilities such as hospitals are rediscovering the natural benefits of using wood to improve both the experience of patients and the performance of staff. There's extensive research being done.

See: www.bregroup.com

PassivHaus

The principles of this movement are concerned with energy efficient design and construction techniques. Wood can help realise such PassivHaus design principles due to many factors such as economic value and low carbon impact. See www.passivhaustrust.org.uk



Timber's aesthetic qualities

Timber is increasingly associated with its positive effect on mental health and wellbeing as it provides us with a connection to nature. Timber is:

- a tactile material that adds warmth and evokes a connection with nature (see [Biophilic Design](#));
- unique, each piece is different in grain and colour, encouraging design innovation;
- easily rejuvenated or decorated.

Timber's environmental benefits

As climate change becomes a growing threat, the carbon footprint of construction and subsequent building use is in the spotlight. Specifying timber has major environmental benefits over other materials.

Wood CO₂ts less

FACT 1

Trees capture CO₂ from the atmosphere and store it as carbon



FACT 2

Mature trees are harvested and their carbon is captured and stored in buildings and other wood products



FACT 3

More trees are planted and the size of the European forest carbon sink continues to grow



FACT 4

Using wood instead of other materials saves CO₂ emissions, both through the carbon captured and stored in the wood product and the avoidance of alternative CO₂-intensive materials



FACT 5

One of the simplest ways to capture carbon and reduce CO₂ in the atmosphere is by increasing the use of wood in construction



FACT 6

Using wood in construction is a cost-free solution to carbon capture – reducing CO₂ in the atmosphere



Wood CO₂ts less is a collective mark of Wood for Good Ltd.

Visit: www.woodforgood.com/co2

- Timber is a renewable resource, with a plentiful supply. Forestry source certification schemes (such as PEFC) ensure sustainable management of both softwood and hardwood forests (see **Compliance: Sourcing Timber**).
- Growing trees absorb CO₂ from the atmosphere. Using wood from sustainably-managed forests instead of other materials is a good way to reduce CO₂ emissions. The expansion of forests encourages and sustains wildlife (see [WoodCO₂tsless](#)).
- Timber requires less energy to produce than any other construction material - i.e. concrete or steel. Contributes to carbon zero emissions targets (see [PassivHaus](#)).
- Timber has a major potential for re-use or recycling at end of life or creating energy from Biomass facilities.

CLADDING DESIGN

Profile shape and board arrangement, coupled with timber species, surface finish and colour options offer infinite design possibilities for timber cladding projects.

Profile styles and board arrangement

There is a wide choice of standard profiles and board widths available in different softwoods, modified woods and hardwoods. Dimensions and styles can vary from one manufacturer to another so always obtain samples before you buy. Bespoke profiles can also be made to order – with many companies offering new and innovative designs.

Due to the way cladding is shaped, fixed and its natural movement (expansion and contraction) characteristic, some profiles are not suitable for both horizontal or vertical arrangements and only Tongue and Groove (T&G) is recommended for diagonal designs.

Table 1: Summary of generic cladding profiles and recommended applications.

PROFILE	CLADDING JOINT	RECOMMENDED ORIENTATION			THICKNESS (mm)	TYPICAL BOARD WIDTH* RANGE
		Horizontal	Vertical	Diagonal		
<p>Tongue & Groove (T&G)</p>	Closed	✓	✓	✓	20mm (minimum)	75 - 125mm
<p>Rectangular</p>	Closed - board on board	✗	✓	✗	16 - 25mm (thicker boards are acceptable)	75 - 150mm
<p>Feather edge</p>	Closed	✓	✗	✗	Thin end: 9mm (minimum) Thick end: 16 - 25mm	75 - 150mm
<p>Shiplap</p>	Closed	✓	✓	✗	18mm (minimum)	75 - 150mm
<p>Parallelogram</p>	Open	✓	✗	✗	16 - 25mm (up to 50mm is acceptable)	75 - 150mm

The table shows standard profiles - there are many variations available with features modified for design variations or secret fixing.

*Width = 4 to 6 times board thickness. It may be possible to go above thickness x6 with very small movement class timber species graded to the highest standards. You can go below thickness x4 so long as you recognise the impact on material and installation costs.

See [Material Selection: Performance – MOVEMENT](#)

Only specify T&G boards that have been manufactured for external cladding applications.

The maximum width for T&G boards is 125mm unless the timber species used is classed as 'very small movement' in which case up to 195mm is possible. Likewise for other profile styles, wider boards are possible with very small movement timbers such as certain modified wood products (ie. Accoya®wood).

For recommended movement gaps and tongue dimensions see [Table 3](#) on page 29.

To the right: standard cladding profiles with varying colour and finishing options shown in different arrangements.

Grey column below: open jointed screening, differing board widths and custom made cladding panels provide more bespoke design options.

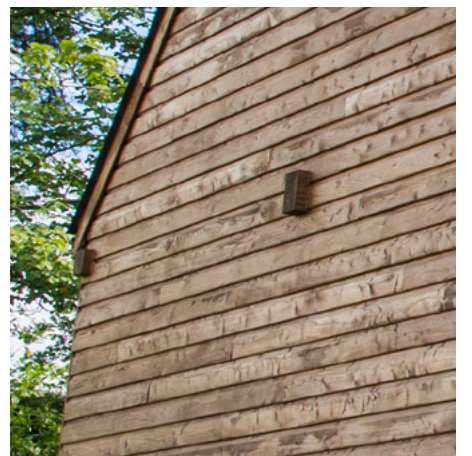
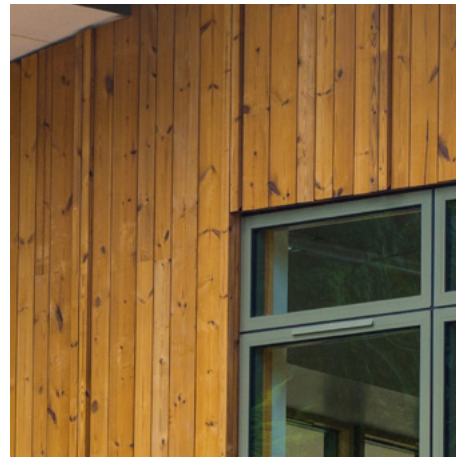
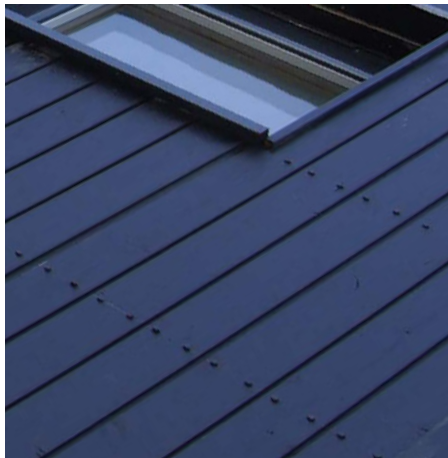

MATERIAL SELECTION

TELL ME MORE >

Use Classes

Visit the WPA's website to learn more about the Use Class system for both **preservative** and **modification** treatments:

www.thewpa.org.uk/preservative-treatments

Heartwood vs Sapwood

The heartwood of some species contains naturally occurring chemicals that make it more durable – the ability to resist decay and insect attack.

Sapwood is a source of food for many species of fungi and insects and is ALWAYS vulnerable to attack.

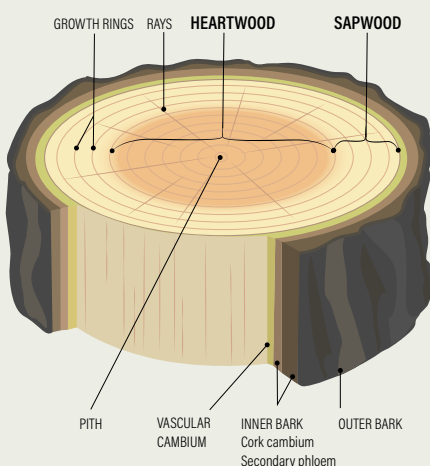

Performance

Before we look at the individual characteristics of particular timber species, let's talk about general performance and the instances in which timber used for cladding may need additional protection or design consideration

DURABILITY (resistance to decay and insect attack)

The timber you choose for your cladding needs to be durable enough to meet the service life you require in what is an **exterior, above ground environment** – this application is categorised in British Standards as a **Use Class 3** end use of wood (BS EN 335 Durability of wood and wood-based products working in tandem with BS 8417 Preservation of Wood Code of Practice).

Durability performance can be either a **natural characteristic** of a particular species or it can be conferred on a **low natural durability** species by **preservative pre-treatment** or a **wood modification** process. The degree of timber's natural durability varies from species to species.

Durability classifications apply to **heartwood** only; the **sapwood** of all species is not durable. Where natural durability is insufficient, factory **impregnation** with a **wood preservative** or the use of a suitable **modified wood** should be specified.

NOTE: Use Class is different to Natural Durability Class – See **Table 2**.

To achieve a **15 year** (or more) **service life expectation** select timber that is EITHER:

- **NATURALLY DURABLE** – a timber species that has appropriate, inherent natural durability for its application;
- **PRESERVATIVE TREATED** – timber impregnated with a wood preservative in a factory-controlled process to meet a minimum **Use Class 3** rating;
- **MODIFIED** – timber physically modified in a process that changes its properties to enhance its durability to an appropriate level.

Table 2: How natural durability of heartwood relates to service life (Ref: BS8605-1)

NATURAL DURABILITY CLASS	DESCRIPTION	DESIRED SERVICE LIFE / YEARS	
		¹ Occasionally wet	Frequently wet
1	Very durable	>60	60
2	Durable	60	30
3	Moderately durable	30	15 ²
4	Slightly durable	15 ²	<15 ²
5	Not durable	<15 ²	<15 ²

NOTES to Table 2:

- 1: Virtually all cladding should be regarded as being in the 'Frequently wet' category unless guarantees can be obtained regarding reduced levels of wood moisture content e.g. with the application of a specialist coating or in a sheltered site with large eaves.
- 2: **Preservative treatment** or **modification** of lower durability species is designed to extend service life to 15, 30 or 60 years.

NOTE: The presence of **untreated sapwood** is not acceptable although a small amount can be tolerated if restricted to the **reverse side of the cladding board**. It should not exceed **5 mm** in depth and **500 mm** in continuous length (ref: BS 8605-1).

TELL ME MORE >



Flame Retardants

Learn more about approved fire protection treatments for timber:

www.thewpa.org.uk/flame-retardants

Learn more about the work of BRE:
www.bregroup.com

BS 8605-1:2014 gives guidance on specifying external timber cladding, including design, performance requirements and moisture content.

FIRE

Wood has good thermal insulation properties, high structural strength and slow charring rate, so its general behaviour in a fire situation is fairly predictable.

However, in areas where the consequence of fire is greater, for example in public buildings such as **cinemas, theatres, libraries, schools, offices, hotels and hospitals**, building regulations are in place governing the use of performance rated, flame retardant building products.

Flame Retardants (FR) generally work by reducing the surface spread of flame, heat and smoke release, providing vital extra time for a safe escape.

Where building regulations or fire assessments stipulate a need for fire protection of timber cladding, we recommend pre-treatment with a quality assured flame retardant applied by a processor approved by the product manufacturer.

NOTE: not all timber species are suitable for FR treatment. Check with product supplier prior to project specification.

The application of flame retardant products to timber cladding on the construction site, by brush or spray is **NOT APPROVED** by the Wood Protection Association (www.thewpa.org.uk) as quality control is almost impossible to assure.

Always seek and adhere to up-to-date national guidance on fire regulations. For more detailed information see Compliance: External Timber Cladding and Fire Risk.

MOVEMENT

Wood is hygroscopic, meaning its moisture content is affected by changes in temperature and relative humidity of the surrounding environment. This results in **movement across the grain of the timber**.

Different species have different degrees of movement and this must be accounted for in cladding design and installation. Shrinkage may result in cladding boards pulling apart and becoming unstable or, exposing uncoated timber on cladding that has been painted or stained after installation. Expansion coupled with inadequate movement gaps during installation can result in boards bowing or pulling away from their fixings (see example below).

See **Installation: Build-up and Design Detail – CLADDING BOARDS**

Ideally, cladding timber should be classed as ‘small’ or ‘medium’ movement (ref: **BRE**).

Designers, manufacturers and specifiers of timber cladding should adhere to the guidelines set out in **BS 8605-1:2014** External timber cladding - method of specifying.

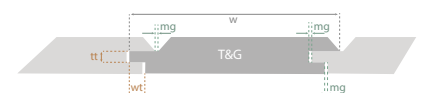
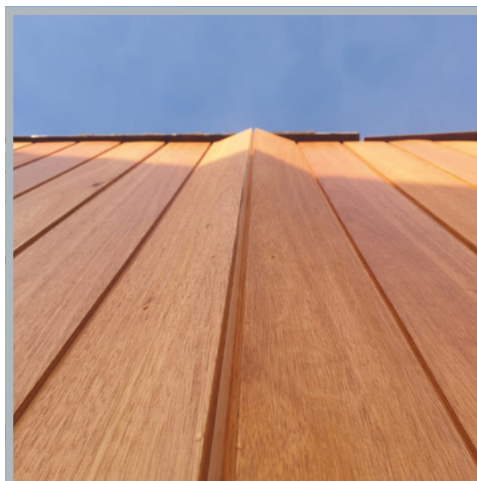

Example: In this situation, the width of the tongue (wt) is too small for the board size (w) in addition to the species and/or board width not meeting recommended guidelines.

This is compounded by the boards being installed with inadequate movement gaps (mg).

TELL ME MORE >

BS8605-1 External Timber Cladding Part 1: Method of specifying cites **BS EN 942, 14519, 14951** and **15146** as being acceptable appearance grading systems.

BS 1186:3 1990 - Timber for and workmanship in joinery

BS EN 942 - Timber in Joinery

Whilst **BS 1186** has been superseded by the harmonised European Standard **BS EN 942** it is still widely referenced in the supply chain and by designers with regard to guidance on the appearance quality of timber for different applications. **BS 1186** details the limits of visual characteristics that can affect the surface of cladding such as: knots, splits, resin pockets, sapwood, exposed pith and grain straightness etc. Modern day manufacturing practices and material approval procedures have largely superseded its use.

Appearance Grading

Timber is a natural grown material with species specific features and attributes – so every piece of timber cladding will look slightly different.

The appearance can be affected by the following characteristics – these will have a bearing on the aesthetics but could also affect the quality of the cladding. To take into account the occurrence of these natural attributes, timber cladding is graded but such grading systems can differ from supplier to supplier.

Examples of typical timber characteristics:

Knots: their type, size, frequency and position

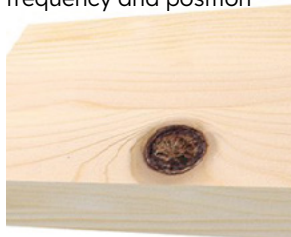

Grain slope



Bark pockets



Spiral grain



End shakes



Resin pockets

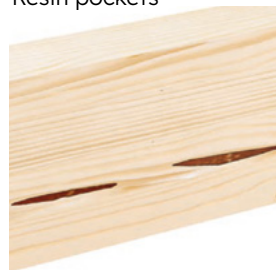

Exposed pith



Ask your supplier to describe in detail (and show you), the grade(s) that they supply.

Depending on the timber species, the supplier may have more than one appearance grade available of the same type of cladding. This will sometimes include batch tolerances (i.e. percentages of cladding within packs which may meet a lower grade).

For obvious reasons, appearance grading criteria reflects the weather exposed face more than the concealed face of the cladding.

Timber Gallery

The following pages illustrate the most commonly available timbers used for cladding, along with performance ratings and some recommendations regarding suitability for treatment, coatings and fixing.

Each species and variety of timber has its own distinct appearance and unique characteristic. Colour, grain, density, number and size of knots and resin content are some trait examples (images shown are for representation only).

Always ensure you are happy with the appearance quality of the material you have chosen before purchasing – most suppliers are happy to provide cladding samples.

Surface appearance alters as the material matures and weathers, especially uncoated cladding. You may add a factory applied or manually applied coating for decoration or extra weathering protection, but this will need maintaining so consider your budget and accessibility.

If you require a factory applied coating, always obtain a finished sample on the proposed timber species cladding profile.

See [Coatings and Finishes](#)

The difference between Softwoods, Hardwoods and Modified woods

Softwood used in cladding generally comes from coniferous trees which are usually fast growing and examples include **pine**, **spruce** and **western red cedar**.

Hardwood used in cladding tends to come from broad leaved trees in temperate climates like **oak**, or from the wide range of tree species that grow in tropical regions of the world.

Hardwood trees tend to grow much more slowly than softwoods and as such they are typically more dense and heavier.

Generally speaking **hardwood** species tend to be more naturally durable, darker in colour, close grained and more expensive than **softwood** (but there are exceptions).

Wood modification is a term used to describe solid timber (predominantly softwood, occasionally hardwood) that has undergone a chemical, biological or physical process. This essentially creates a new timber product with enhanced performance properties – principally the improvement of durability.

The majority of **modified woods** used in cladding are rated as Very Durable (BS EN 350 Class 1) or Durable (Class 2) and capable of delivering a desired service life of 30 years or more.

Depending on the species and process used, each brand of modified wood has different appearance and performance attributes. Some suppliers offer long service life warranties on their modified wood cladding products.



Felled (softwood) Larch logs

Timber Gallery

SOFTWOODS

Douglas Fir	VARIETY / ORIGIN	ALSO KNOWN AS	NATURAL DURABILITY CLASS*	MOVEMENT CLASS	DENSITY kg/m ³	AVAILABILITY
	UK	British Columbian pine, Columbian pine	3 - 4	small	470 - 520	Specialist supplier
	North American	Oregon pine	3	small	510 - 550	Good

Heartwood is light reddish-brown, usually quite distinct from lighter sapwood with clearly marked annual growth rings.

Very tough softwood
UK variety is knottier which can encourage a more wavy grain.

Western Red Cedar	VARIETY / ORIGIN	ALSO KNOWN AS	NATURAL DURABILITY CLASS*	MOVEMENT CLASS	DENSITY kg/m ³	AVAILABILITY
	UK		3	small	330 - 390	Specialist supplier
	North American /Canadian		2	small	330 - 390	Good

Reddish brown in colour. Stable and very light in weight. Does not contain resin and is therefore ideal for painting and staining but is equally suited to be left to weather naturally.

Take care handling as relatively soft and brittle. UK variety is knottier but cheaper.
A good finish can be obtained, but cutters must be kept sharpened and care is needed in order to obtain the best results during mortising, planing and moulding.
Stainless steel fixings must be used.
May blacken where high pollution exists.

Larch	VARIETY / ORIGIN	ALSO KNOWN AS	NATURAL DURABILITY CLASS*	MOVEMENT CLASS	DENSITY kg/m ³	AVAILABILITY
	European / UK	-	3 - 4	small	470 - 650	Specialist supplier
	Siberian	Russian larch	3 - 4	small/medium	680 - 700	Good

European = Dark pink. Siberian = straw colour. Prominent growth rings, straight grained, fine uniform texture. Dense, heavy and hard wearing. Easy to machine and saw.

Heartwood is moderately durable, sometimes slightly durable –may require pressure treatment.
Is very resinous so best left natural (uncoated) but will take exterior grade oils.
Use screw fixings as tends to split on nailing, pre-drilling recommended particularly at board ends.
Best for simpler, overlapping profiles due to movement properties. Not recommended for T&G profiles > 120mm wide.

* Where durability class is shown as a range, the lowest durability (highest number) should be assumed unless specific information is available on the source of the wood to be used (see Table 2).





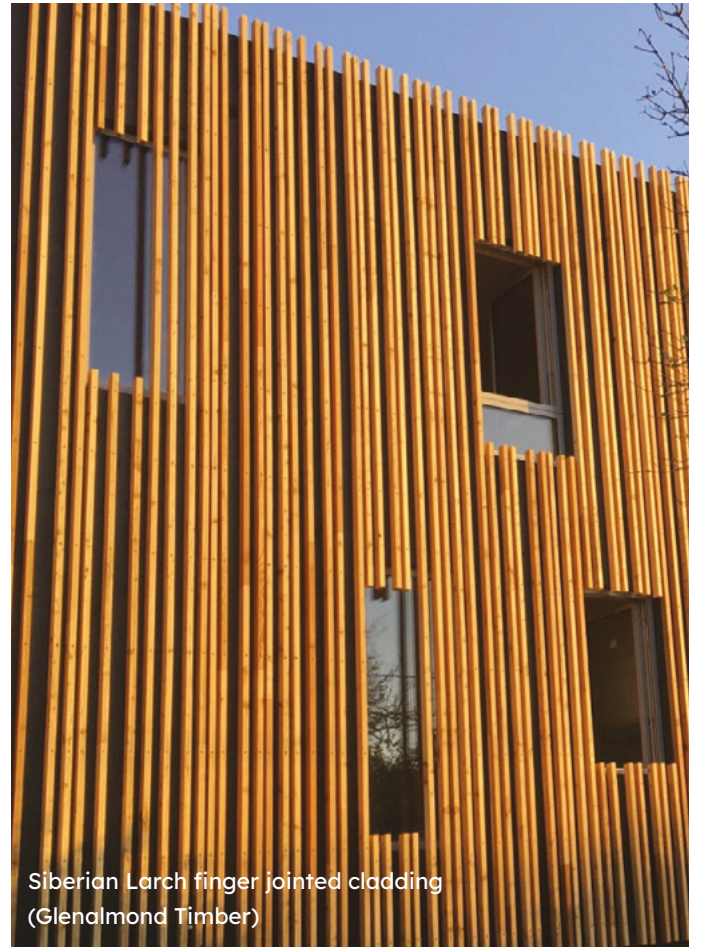

British Larch Cladding in a shiplap profile
(BSW Timber)



Siberian Larch finger jointed cladding
(Glenalmond Timber)



Western Red Cedar
cladding (Silva Timber)



Pine	VARIETY	ALSO KNOWN AS	NATURAL DURABILITY CLASS*	MOVEMENT CLASS	DENSITY kg/m ³	AVAILABILITY
	Scots	European /Baltic redwood (UK)	3 - 4	medium	500 - 540	Good
	Lodgepole	Contorta pine (UK)	3 - 4	small	430 - 470	Good
	Radiata	Insignis (South Africa), Monterey pine (USA)	4 - 5	medium	420 - 500	Specialist supplier
	Southern	American / Gulf Coast/ long leaf pitch pine, southern yellow pine (USA), loblolly pine	4	medium	650 - 670	Good

Generally pale in colour, ranging from yellowish - pink to reddish - brown heartwood with growth rings clearly visible. Lodgepole has fine, even texture with soft, straight grain. Radiata and Southern have medium textures and Scots is coarse.

All varieties take nails and screws and give fair results with coatings.
 Dependant on grade, all varieties are generally easily worked and capable of a smooth clean finish.
 Generally all Pine cladding requires preservative treatment to achieve suitable durability.

Spruce	VARIETY	ALSO KNOWN AS	NATURAL DURABILITY CLASS*	MOVEMENT CLASS	DENSITY kg/m ³	AVAILABILITY
	Sitka	Silver / tideland / Menzies spruce	4 - 5	small/ medium	400 - 450	Good
	Norway	European Whitewood	4	medium	440 - 470	Good

No difference in colour between sapwood and heartwood, Sitka usually has a pinkish tinge, Norway colour varies from almost white to pale yellowish-brown. The growth rings are not so prominent. It has a straight grain and a good texture.

All varieties take nails and screws well and give fair results with coatings.
 Dependant on grade, both varieties are generally easily worked and capable of a smooth clean finish.
 Generally all Spruce cladding requires preservative treatment to achieve suitable durability.

* Where durability class is shown as a range, the lowest durability (highest number) should be assumed unless specific information is available on the source of the wood to be used (see Table 2).

Timber Gallery

HARDWOODS (TEMPERATE)

Temperate forests grow between the tropics and the Polar Regions in both the Northern and Southern Hemispheres. They generally have four distinct seasons with a well-defined winter. The UK imports temperate hardwood predominantly from Europe and North America.

	SPECIES / ORIGIN	ALSO KNOWN AS	NATURAL DURABILITY CLASS*	MOVEMENT CLASS	DENSITY kg/m ³	AVAILABILITY
	American White Oak	chestnut oak, overcup oak, swamp chestnut oak	2 - 3	medium	670 - 770	Good

Variable colour from pale yellow-brown to pale reddish-brown, often with a pinkish tint. Attractive grain, mainly straight with medium to coarse texture. Quality depends greatly on the conditions of growth.

Corrosive to metals due to acetic acid – specialist fixings to be used.
 Prone to leaching of extractives.
 Good drilling and finishing performance and machines well.

	SPECIES / ORIGIN	ALSO KNOWN AS	NATURAL DURABILITY CLASS*	MOVEMENT CLASS	DENSITY kg/m ³	AVAILABILITY
	European Oak	English oak, French oak, Slovenian oak, Polish oak	2 - 4	medium	650 - 760	Good

Heartwood is light to dark brown and distinctive from sapwood. Mostly straight grained with a medium to coarse texture. Quality depends greatly on the conditions of growth. UK grown timber may be available

Corrosive to metals due to acetic acid – specialist fixings to be used.
 Prone to leaching of extractives.
 Good drilling and finishing performance and machines well.

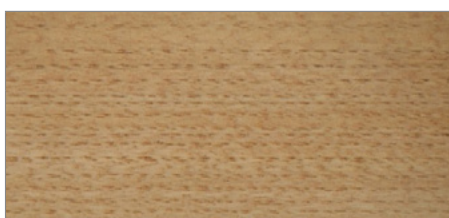
	SPECIES / ORIGIN	ALSO KNOWN AS	NATURAL DURABILITY CLASS*	MOVEMENT CLASS	DENSITY kg/m ³	AVAILABILITY
	Sweet Chestnut	European chestnut (Europe), Spanish chestnut (Spain)	2	small	540 - 650	Specialist supplier

Heartwood is light to medium brown and distinctive from sapwood. Grain is may be straight but is often spiral particularly from older trees. UK grown timber may be available.

Corrosive to metals – specialist fixings to be used.
 Prone to leaching of extractives and discolouration when it comes into contact with iron compounds.
 Machines well. Nailing and screwing properties are good

* Where durability class is shown as a range, the lowest durability (highest number) should be assumed unless specific information is available on the source of the wood to be used (see Table 2).

Timber Gallery

HARDWOODS (TROPICAL)

Tropical forests can be found in Central and South America, West and Central Africa and South East Asia. Care should be taken to ensure your timber is from a legal and sustainable source. See **Compliance: Sourcing Timber**

	SPECIES / ORIGIN	ALSO KNOWN AS	NATURAL DURABILITY CLASS*	MOVEMENT CLASS	DENSITY kg/m ³	AVAILABILITY
	Cumaru South & Central America	Tonka (Surinam, French Guiana), Almendrillo (Bolivia), Sarrapia (Colombia)	1	small	1100 - 1150	Good

Heartwood medium to dark brown sometimes with reddish or purple hue. Has a waxy / oily feel, medium texture and irregular often interlocked grain. Heavy, hard and tough.

With sharp tools it saws and bores cleanly, and when severely interlocked grain is absent it planes and finishes to a smooth surface.

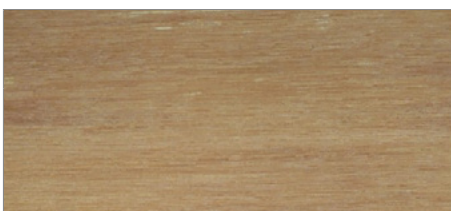
	SPECIES / ORIGIN	ALSO KNOWN AS	NATURAL DURABILITY CLASS*	MOVEMENT CLASS	DENSITY kg/m ³	AVAILABILITY
	Garapa South America	Pau Mulato, Grapia, Ferro (Brazil)	3	medium	700 - 900	Specialist supplier

Heartwood varies in colour from yellowish-brown to pinkish-yellow, acquiring a reddish or coppery hue after exposure. Lustrous, with a straight grain (occasionally interlocked) and fine, uniform texture. Hard, heavy, tough and strong.

Moderately easy to work, finishing smoothly although the high silica content causes blunting to tools.

	SPECIES / ORIGIN	ALSO KNOWN AS	NATURAL DURABILITY CLASS*	MOVEMENT CLASS	DENSITY kg/m ³	AVAILABILITY
	Iroko Africa	odum (Ghana / Ivory Coast), mvule (East Africa), kambala (Zaire), bang (Cameroons), moreira (Angola), tule, intule (Mozambique)	1 - 2	small	630 - 670	Good

Heartwood is yellow to golden brown colour. The grain is usually interlocked and the texture coarse.

Medium workability and an excellent finish can be obtained if the grain is filled (not interlocked).

Large, hard deposits of calcium carbonate called 'stone' deposits, are sometimes present in cavities and often not visible although the wood around them may be darker in colour. Be aware when sawing as they dull the cutters. Takes nails and screws well.

	SPECIES / ORIGIN	ALSO KNOWN AS	NATURAL DURABILITY CLASS*	MOVEMENT CLASS	DENSITY kg/m ³	AVAILABILITY
	Red Grandis Uraquay	Eucalyptus / Rose gum, Flooded gum	3 ¹	medium	610	Specialist supplier

Colour can vary, almost white to light pink or dark red. Be wary that the sapwood does not vary significantly from the heartwood. Texture is fine. Strong, like oak and hard. Grain may be interlocked although plantation stock is generally straighter grained. ¹ Durability assessed in laboratory tests rather than field tests.

Moderately workable with some difficulty in planing due to occasional interlocked grain. Good nailing and screwing properties. Accepts a good finish.

* Where durability class is shown as a range, the lowest durability (highest number) should be assumed unless specific information is available on the source of the wood to be used (see Table 2).

MATERIAL SELECTION:

Timber Gallery

HARDWOODS (TROPICAL)

	SPECIES / ORIGIN	ALSO KNOWN AS	NATURAL DURABILITY CLASS*	MOVEMENT CLASS	DENSITY kg/m ³	AVAILABILITY
	Red Louro South/Central America	Louro vermelho (Brazil), Gamela (Brazil), Determa (Guyana), Wana (Surinam)	2	small/medium	600 - 650	Specialist supplier

Deep salmon red when freshly cut, becoming a light reddish-brown with a golden sheen when dried. Grain is straight or interlocked. Texture is coarse and uniform. Not as strong as other tropical hardwoods.

Easily worked. Good weathering characteristics with very little surface degrade in uncoated wood.

* Where durability class is shown as a range, the lowest durability (highest number) should be assumed unless specific information is available on the source of the wood to be used (see Table 2).



Garapa
(Woodtrend)



'Weathered' Chestnut
(Ecochoice)



Cumaru
(Woodtrend)

MODIFIED WOOD

TELL ME MORE >

Enhanced durability and stability characteristics are a key factor in improving **coating performance** on modified wood (compared to the performance levels on base timber species).

See [Coatings and Finishes](#)

The principal aim of modification is to improve durability but dimensional stability may also be improved. Other characteristics like strength and density can be affected but this is not normally an issue for cladding applications.

Wood modification falls into 3 process categories -

- **Thermal Modification:** a physical process such as heating or heat and pressure.
- **Chemical Modification:** a chemical process which alters the water binding cells.
- **Physical Modification:** a combination of processes that may include physical, chemical or even biological factors.

The properties and aesthetics of modified woods differ in relation to the original species, the process and variations in process. They are brand specific and it is always best practice to consult the manufacturer for up-to-date performance information.

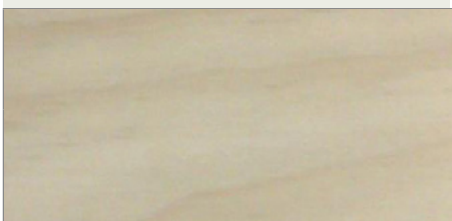
	BRAND NAME	MODIFICATION PROCESS	BASE TIMBER SPECIES	ASSIGNED NATURAL DURABILITY CLASS	DENSITY kg/m ³	MOVEMENT CLASS
	Accoya® Wood	Chemical	Radiata Pine	1	435 - 595	Very small
Light straw in colour. Outstanding dimensional stability and durability - even in ground or permanent water contact. Moisture content less than 8%						
Accoya has a 50-year warranty against rot and fungal decay in above-ground applications. Easy to machine and process. Appropriate coatings work extremely well - opaque finish is recommended (to prevent discolouration and uneven weathering).						

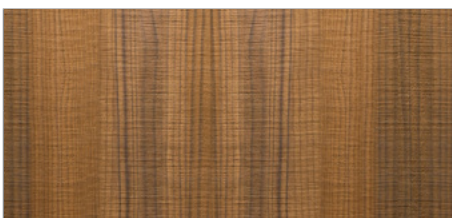
	BRAND NAME	MODIFICATION PROCESS	BASE TIMBER SPECIES	ASSIGNED NATURAL DURABILITY CLASS	DENSITY kg/m ³	MOVEMENT CLASS
	Abodo®	Thermal	Radiata Pine	1	430	Small
Rich dark brown in colour. Virtually knot free. Good dimensional stability and durability. Low moisture content 7-9%						
Abodo cladding should be coated with an approved protective finish. It is not recommended to leave uncoated. Cladding should be sanded, bandsawn or otherwise textured prior to applying coating. Readily accepts flame retardant treatments, oils and stains.						

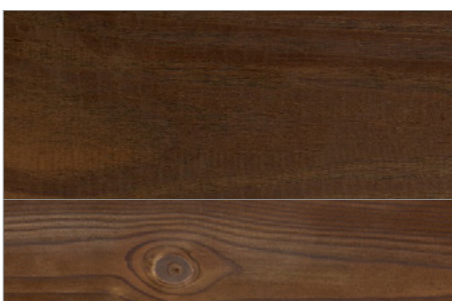
	BRAND NAME	MODIFICATION PROCESS	BASE TIMBER SPECIES	ASSIGNED NATURAL DURABILITY CLASS	DENSITY kg/m ³	MOVEMENT CLASS
	Kebony (Clear)	Chemical	Radiata Pine	1	670	N/A ³
	Kebony® (Character) ²	Chemical	Scots Pine	1 - 2*	570	N/A ³
Very dark brown in colour but weathers to silvery grey. 'Clear' is virtually knot free with 'Character' containing more knots. Good dimensional stability and durability.						
2: Kebony Character contains untreated heartwood - cladding should not be further machined, or split but can be cross cut to length, exposed end grain must be treated with a wood preservative.						
3: Information not readily available - refer to manufacturer.						

* Where durability class is shown as a range, the lowest durability (highest number) should be assumed unless specific information is available on the source of the wood to be used (see Table 2).



Accoya with charred effect (Accsys)



Accoya (Accsys)



Abodo (Glenalmond Timber)

Timber Gallery

MODIFIED WOOD
(continued)

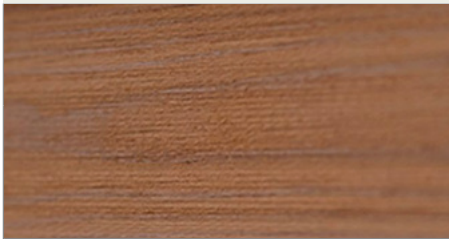
	BRAND NAME	MODIFICATION PROCESS	BASE TIMBER SPECIES	ASSIGNED NATURAL DURABILITY CLASS	DENSITY kg/m ³	MOVEMENT CLASS
	ThermoWood® D	Thermal	Scandinavian (Scots) Pine or Spruce	2	350 - 480	N/A ³

Rich brown in colour. Good dimensional stability and durability. Low moisture content 5-7%

Tends to be quite brittle, take care when handling.

Nail/screw holding capability is around 20% less than usual - use stainless steel.

Can be left uncoated to weather naturally.

If coated, only vapour permeable, 'Low- build' stains are recommended for exterior use.

3: Information not readily available - refer to manufacturer.

* Where durability class is shown as a range, the lowest durability (highest number) should be assumed unless specific information is available on the source of the wood to be used (see Table 2).





Example of weathered larch cladding next to newly installed, unweathered boards.



Coatings perform better on a sawn finish (left) rather than a smooth planed surface (right).



Finishes and Coatings

Many cladding timbers can be left uncoated to weather naturally - changing in appearance with exposure to the elements. Adding a coating may be a recommendation of the supplier/manufacturer for a particular species or type. When deciding whether or not to use a surface coating or finish there are factors you should consider.

- **The aspect of the cladding:** south or west facing are more exposed to both sunlight and driving rain so will weather more quickly. Northerly or eastern facing walls will be shaded and appear darker and may and may require more frequent maintenance.
- **Shade from a canopy, overhanging trees or nearby buildings** may also have a localised impact and cause variations in colour on the same elevation.

To counteract these factors or simply to add another dimension to your cladding, various types of coatings and finishes are available. Many have **water repellent** and/or **UV protection** built-in. There are **translucent paints and stains** offering partial colour effects and **solid pigmented coatings** which give a completely opaque look. Most **clear oils** are of limited use - refer to product supplier for guidance.



Recommendations

- **Factory applied coatings with an extended maintenance system are best for long term performance.** Many timber cladding suppliers offer this service.
- **Surface coatings work best on timbers that are dimensionally stable or have a low potential for moisture change movement.** The process of **preservative treating** or **modifying wood** generally has a positive impact on coatings adhesion. Always check with manufacturer*.
- **Surface texture is important.** Coatings generally perform better applied to **SAWN** rather than **smooth planed** timber.
- **Moisture permeable coatings are highly recommended.** Specially developed for external timber, they are resistant to cracking, flaking and peeling associated with more brittle varnishes or paints which can trap water under their surface.
- **Highly pigmented coatings resist weathering best.** Paler colours, especially white, also reflect the heat.

* NOTE: In terms of **flame retardant treated cladding**, any decorative coating applied **must not downgrade the performance of the fire rated timber** - check with product manufacturers.

In order to deliver the desired service life, any coating applied must be maintained in accordance with the manufacturer's guidance. The ease of access, requirement for maintenance and budget may determine what kind of coating system you choose.

Recommendation for application of on-site coatings (read manufacturer's instructions):

- at least **one coat** should be applied to **all faces** including the end grain, prior to **installation**. Further coats can then be applied to the **visible face** see: **Maintenance**.



Contemporary cladding finishes

The ancient Japanese technique of charring the surface of wood, known as **yakisugi-ita** (or just **yakisugi**), can be used to create a blackened charcoal finish to timber cladding boards. Supplied by specialist companies, the surface is charred and then often brushed and coated with a natural oil. The surface of the wood can take on a crackled or alligator skin appearance.

The resulting aesthetic is proving highly popular with architects who wish to achieve a very black, textured and contemporary finish to their cladding projects.

Many suppliers are offering these techniques on a variety of wood species and in colour variations. However, not all 'charred' timbers are the same.

The durability or weathering properties of the cladding is not improved by the 'charring' process. The performance of the 'charred' timber cladding will depend on the base species used and the quality control of the charring method. Be sure to research your supplier carefully and obtain written confirmation of the product's durability.



Charred Accoya® (James Latham / Shou Sugi Ban® charring process by Exterior Solutions Ltd)

Textural effects

In addition to coloured coatings and finishes, some suppliers offer added textural elements for cladding timbers, or even bespoke and intricate patterns.



IRO cladding in 'Mountain' (BSW Timber)

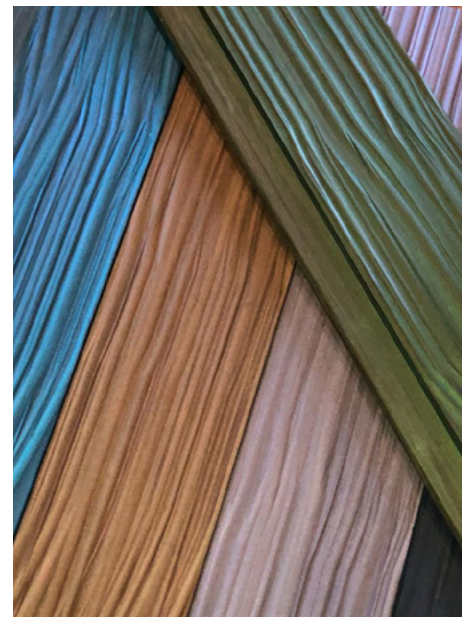

Abodo cladding with 'Riven' texture and metallic coating (Glenalmond Timber)

CLADDING INSTALLATION

TELL ME MORE >

To measure the average moisture content in wood, random tests on a number of pieces of wood should be conducted with a moisture meter.

Read more about moisture content here: <https://www.swedishwood.com/wood-facts/about-wood/wood-and-moisture/>

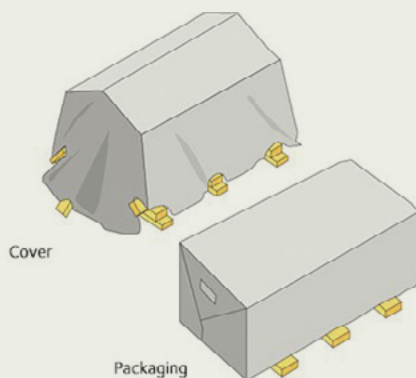

Storing timber

When purchasing timber from a merchant or supplier it's worth asking the supplier to confirm how the product has been stored as this could affect the quality of timber prior to installation. To preserve the quality of the wood until it is in situ in the final structure, it should be **protected from precipitation, sun, dirt and ground moisture**. The same rules apply if storing timber yourself before or during installation.

DELIVERY

- **Plan deliveries** to match the pace of production – order materials in batches.
- **Prepare** for the arrival and storage.
- Ensure the wood is delivered **in packaging** (not transparent).
- **Inspect the wood when taking receipt of the delivery** – does it match what you ordered, is it in good condition?
- Put in a complaint about the wood immediately if, on delivery, it has a moisture content or grade that **does not match the order**.



STORAGE

- **Store outdoors** away from direct sunlight, rain and dirt.
- If moisture content is higher than 16% measures must be taken to allow the product to **dry before installation** (see below: [Moisture Content](#)).
- Choose a storage place where **water will not pool under the wood**, the ground should be cleared of any snow.
- Support at least **300mm off the ground**, preferably not on soil to avoid splash back.
- **Lay flat**, with enough clean support battens at intervals to prevent bending.
- **Cover the wood** (i.e. tarpaulin) so that the air can circulate and so as to avoid high temperature or condensation.
- Ventilate between the wood and the tarpaulin and make sure that the tarpaulin ends a good way above the ground.

Moisture Content

If water has made its way into the pack, the wood must be dried before use. Break open and remove the packaging. Sticker the wood. Cover and leave to dry. Place it in an open location if during the summer. Wood that has warped should be discarded.

Place it indoors with a construction fan if it is a cold time of year. Check the moisture content and the surface moisture content before the wood is to be used.

All drawings are for illustrative purpose only and are not to scale.

+ see note on **CAVITY BARRIERS**

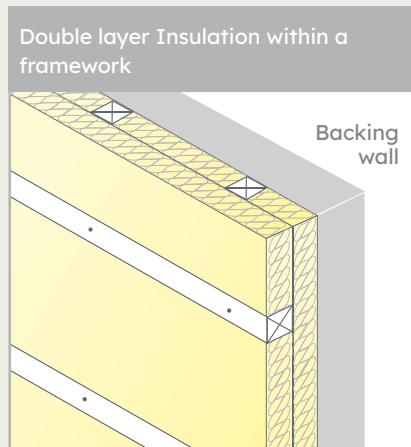
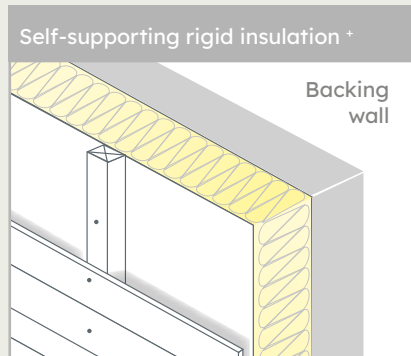

Thermal Bridging occurs in a building where there is a gap in the insulation such as a join or corner or where a structural element spans across thermal insulation (for example in timber frame panels).

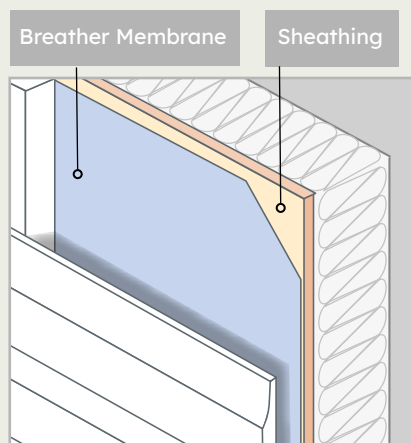

Build-up and Design Detail

The fundamental aspects of installing cladding, can be broken down like this:

- The external cladding assembly is in the **wet zone** of the external wall.
- Cladding is fitted over a **drained and ventilated cavity**, vented top and bottom.
- A breather layer separates dry and wet zones.

On pages 30 - 33 you will find design detail drawings showing basic principles of cladding build-up, covering arrangements for both **vertical** and **horizontal** cladding applications on both **timber frame** and **masonry** exterior buildings in addition to **external and internal corner** arrangements.

Here are the key elements associated with cladding installation build-up:

INSULATION

To achieve a required thermal performance, it might be necessary to add an insulation layer to the outer face of the backing wall but behind the timber cladding assembly.

- The insulation should be either: **rigid, fixed to the backing wall and able to carry the cladding battens directly*** or be carried within a framework of timber battens or I-joists in a **double layer arrangement** to prevent **thermal bridging**.
- The insulation layer should be no more than **100mm thick** unless the support assembly is designed to take lateral loads..
- If used, insulation should be **firmly fixed and properly supported**.
- Joints between adjacent pieces of insulation should be tight, with **no gaps greater than 5 mm wide**.

SHEATHING

A sheet material fixed to a frame in order to give it racking resistance (to resist lateral loads caused by wind). It is used in wall assemblies **onto which other materials can be applied**. If situated in the wet zone of the design it needs to be **water resistant**.

- Sheathing has a load bearing function and it needs to **resist all lateral loads** on the building such as wind. Sheathing thickness typically ranges from 9mm to 18mm depending on the anticipated lateral loads.
- OSB3 (oriented strand board), is commonly used as sheathing. Water resistant plywood can also be used but this is much less common. **Both solutions require a breather membrane to be used on top**.

BREATHER MEMBRANE

Protects against wet weather penetration whilst allowing moisture from behind it to escape.

- Where cladding is fitted to an existing building with solid walls, the wall should be given a waterproof coating, membrane or latex impregnated insulation board. A breather membrane is not essential for cladding fixed to a masonry building with cavity walls.
- The product should be highly durable and tear resistant with water vapour resistance greater than 0.25 MN-s/g and less than 0.6 MN-s/g
- **UV resistant** breather membranes should be used with **open joint cladding** assemblies, the supplier will indicate a maximum allowable gap for its product.

Build-up and Design Detail

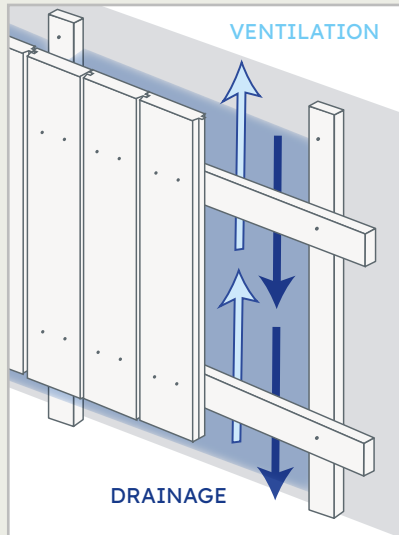

CAVITIES

Drainage and ventilation

Timber cladding provides a form of weather protection. But not all wind driven rain will be deflected, so a **well-ventilated, free draining cavity** should always be included in the detailed design.

Open at the top and bottom to allow through ventilation, a cavity channels any moisture that might enter, back to the building's exterior. By using a series of **timber battens**, a cavity between the cladding and the backing wall structure can be created.

- Whilst cavity ventilation only needs a **minimum gap of 6mm**, the depth will be dictated by the thickness and arrangement of the battens.
- Fit **insect mesh** to all openings to prevent access by small mammals and large insects into the cavity (*you cannot effectively exclude very small insects*).
- Metal vermin mesh is needed at the base of all cavities near the ground.

CAVITY BARRIERS: Minimising the risk of flame spread

Unfortunately, cavities in the external wall of any building can act as a chimney and provide an easy route for flame, hot gases and smoke to propagate from one compartment of a building to another*. Unsealed cavities can allow air to be drawn in and smoke to vent out, enabling the fire spread to accelerate through the façade.

± By utilising carefully selected vertical and horizontal cavity barrier products to sub divide and compartment concealed cavities, the rapid spread of fire from one compartment to another can be prevented.

Creating typical cavity barriers within a timber cladding facade - if required by building regulations (dependant on many factors including type of building):

- The vertical barriers can be formed of **timber battens** at least 38mm thick.
- The horizontal cavity barriers must permit vertical through ventilation **except during fires** and so can be formed using **intumescent strips**.
When exposed to high heat, intumescent strips are triggered to expand, closing any gaps to stop the fire spreading for a period of time. They usually come with either 30 or 60 minutes of fire resistance.
- *Cavity barriers must be **fixed back to solid construction**, they should not just be fixed to the insulation. This might require secondary timber battens within the insulation layer to carry the cavity barriers.
- Attention must also be given to cavities around window and door openings

On matters regarding compliance with fire safety, always consult an architect and/or structural engineer to assure safety through design and adherence to current building regulations.

TELL ME MORE >

*The risk is most acute in multi-storey buildings.

± External fire spread can be limited in several ways, including internal methods and as such are covered in statutory documents supporting national fire regulations.

BS 9991 requires that the flame spread over or within an external wall construction should be controlled to avoid creating a route for rapid fire spread bypassing compartment floors or walls. **This is an important consideration for any fire strategy but is of fundamental importance when a 'stay put' strategy is in place.**

See **Compliance: External Cladding and Fire Risk**.

Build-up and Design Detail

NOTE: An alternative to a wholly timber batten support assembly is a proprietary metal framework or timber support battens carried on metal brackets. In both instances, the installation can be designed by the framework / bracket supplier.

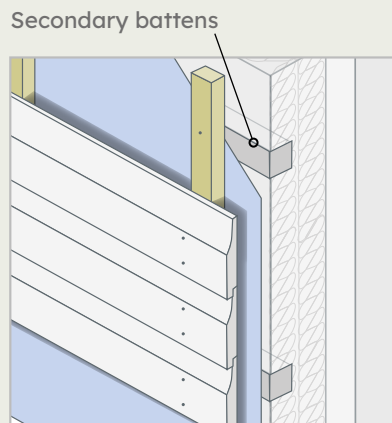

Secondary battens usually behind a **breather layer** are normally designed by the structural engineer who is responsible for design of the backing wall.

MINIMUM BATTEN SIZES mm (w x t)

Vertical batten	
with allowance for side jointing*	50 x 38
no allowance for side jointing*	50 x 25
Horizontal batten	
	50 x 38
Counter batten	
	50 x 25

* Where a short batten length is fixed alongside a batten to enable boards to be butt jointed (see below).

Double batten arrangement for abutting boards

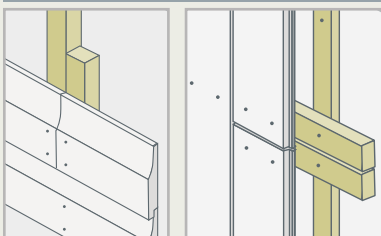

TIMBER BATTENS

Timber cladding boards are usually fixed to timber battens (which are secured to the backing wall) to create a drained and ventilated cavity separating the outer leaf from the structural substrate.

- Horizontal cladding is fixed to **vertical battens** (a).
- **Vertical cladding** is installed onto **horizontal battens** (b), which because they obstruct drainage and ventilation are generally separated from the wall using vertical 'counter' battens - except **board-on-board** (c)*.

Batten Types

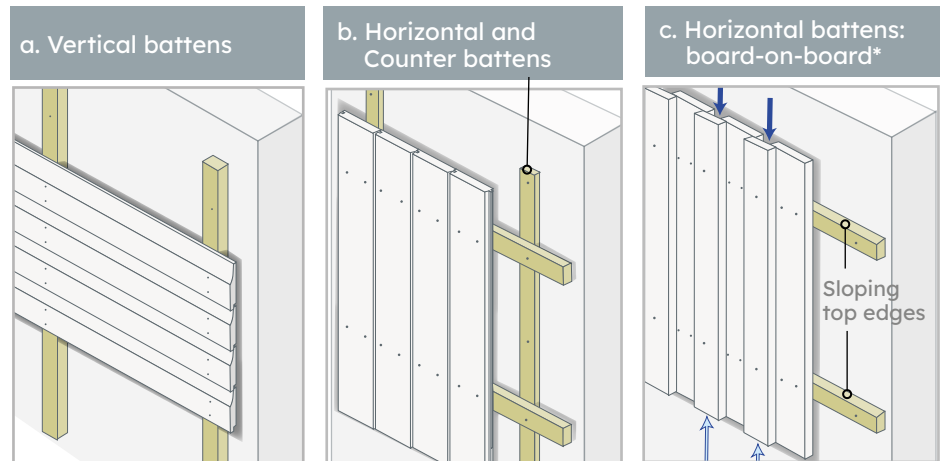

* Board-on-board closed joint arrangements create an uneven rear face which permits cavity drainage and vertical through ventilation. No counter batten is needed providing that the horizontal battens have a sloping forward top.

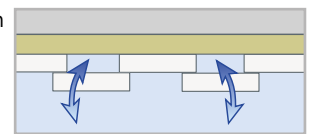

Best Practice

- Space vertical battens at **600mm centres** (max) but for diagonal cladding or for boards with high moisture content (e.g. green oak) use **400mm centres** (max).
- Horizontal batten spacing varies dependant on expected wind loads, especially when used with a counter batten arrangement, typically between 200 - 400mm. (seek specialist advice or refer to the 4th edition of TRADA's External Timber Cladding manual).
- The batten material should be capable of delivering at least **the same desired service life** as the selected cladding board and should be capable of taking fixings without splitting - observe minimum dimensions.
- Typical batten species include **British or Irish grown pine, spruce or larch**. Imported **redwood, whitewood, spruce, pine, fir, and southern pine** is also used. All of these softwood timbers however, must be **preservative pressure treated to a Use Class 3 level of protection** (ref. BS 8417) to ensure adequate durability.
- **Documented evidence** should accompany the product and include supplier name, species, size, grade and treatment specification.
- Where cladding boards are **flame retardant treated**, the battens should be treated to at least the same standard. **Always obtain evidence of treatment**.
- The battens need to be **visually graded** to remove any defects that might affect their performance (refer to the 4th edition of TRADA's External Timber Cladding manual).
- Use **double battens** (side jointing) where ends of two boards abut (try and avoid where possible).
- Also refer to **Tables 4, 5 and 6 in Installation: Metal Fixings section**.

TELL ME MORE >

As timber dries, it shrinks around and across the grain. This can cause boards to ‘cup’ away from the centre growth rings. If a cladding board is nailed with the heart side against the battens, as it dries the edges will curl forward. If nailed with the heart side facing out, the edges push back against the battens and the board stays relatively flat.

Any non-symmetrical profiles will generally be machined so that the heart side is front facing. For sawn boards or symmetrical profiles, look at the curved growth rings on the end of the board.

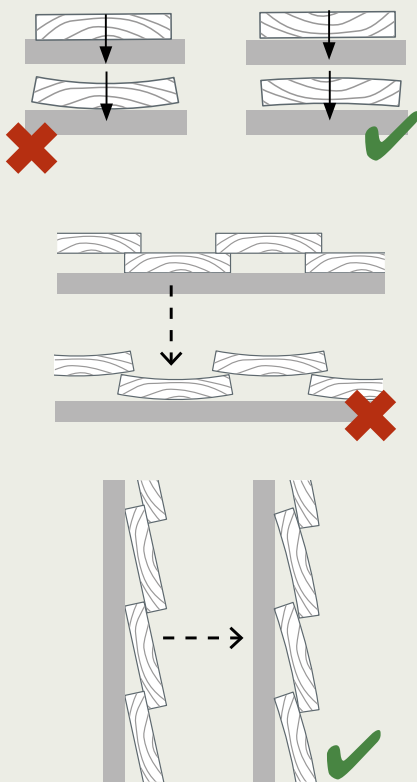

CLADDING BOARDS

Make sure you have considered the **profile and species** when selecting a cladding board - as detailed earlier in this handbook see **Cladding Design and Material Selection**. Some profiles are not suitable for either horizontal or vertical arrangements and only Tongue and Groove (T&G) is recommended for diagonal designs.

- Only use timber suitable for **exterior above ground use**.
- Timber cladding should be supplied/used with a **moisture content of 16 (+/-4) %** (unless using green oak – specialist knowledge required)
- If you **cross-cut any pressure treated timber** on site, re-coat the cut ends with **end grain wood preservative** as per manufacturer’s instructions to maintain the integrity of the treatment.
- Make sure the design and installation will accommodate the **natural seasonal movement** of the timber by paying attention to correct **movement gaps and/or overlaps** for the profile and species used.

Table 3. Minimum movement gaps for T&G and shiplap profiles and Minimum tongue dimensions for T&G profiles (ref: BS 8605)

BOARD WIDTH (w) mm	TONGUE & GROOVE PROFILES					
	Minimum Movement Gap (mg)		Minimum Tongue Width (wt)		Minimum Tongue Thickness (tt)	
	SMALL movement species	MEDIUM movement species	SMALL movement species	MEDIUM movement species	SMALL movement species	MEDIUM movement species
50	2 mm	2 mm	8 mm	8 mm	5 mm	5 mm
75	2 mm	2 mm	8 mm	9 mm	5 mm	5 mm
100	2 mm	3 mm	8 mm	12 mm	5 mm	6 mm
125	2 mm	4 mm	10 mm	15 mm	5 mm	7.5 mm
150	3 mm	-	12 mm	-	6 mm	-
175	3 mm	-	14 mm	-	7 mm	-
200	4 mm	-	16 mm	-	8 mm	-

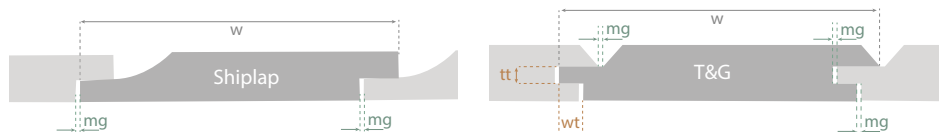

Open jointed cladding

Requires specific technical considerations, including:

- Leave a space of **8 - 15mm** between boards depending on width and overall project design – too big a gap will expose the outer wall structure.
- **UV resistant breather membranes** should be used with open joint cladding assemblies, the supplier will indicate a maximum allowable gap for its product.



Contact **TDCA** for further information.

Build-up and Design Detail

All drawings are for illustrative purpose only and are not to scale.

Fixings placed at quarter points

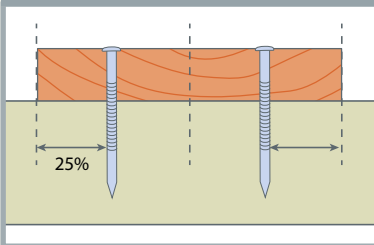

Minimum 20mm from board end

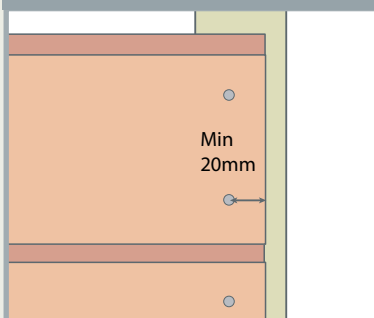

Fixing positions

The risk of timber splitting and fixings ‘pulling through’ is minimised by the way you fix the boards to the battens.

- Only use fixing types suitable for exterior use (see **Installation: Metal fixings**).
- **Through the face fixing** is the most secure way to install timber cladding, ensuring fastener is flush with the surface.
- Use **two fixings** at each cladding board / batten intersection placed at **quarter points** of board width unless the board is less than 100mm wide when one fixing can be used. Fixings should be a minimum of 20mm in from board ends.
- Where **concealed fixing** is required then boards may be back fixed to counter battens or installed using a **proprietary metal fastening bracket or support system**. **Concealed fixing systems are best used in the prefabrication of cladding panels.**
- Nail and screw dimensions should be relative to board thickness /density and be able to adequately secure the cladding. Refer to manufacturers recommendations for specific fixing types and see **Installation: Metal fixings**.

Standard horizontal cladding fixing (cross section from side view)

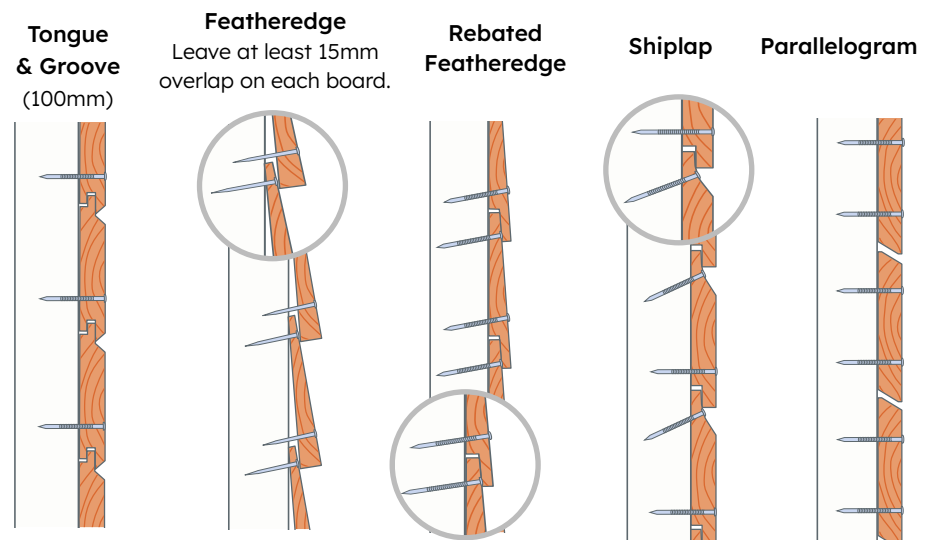

Tongue and Groove profile cladding board - fit with the tongue pointing upwards

Standard vertical cladding fixing (cross section from top view)

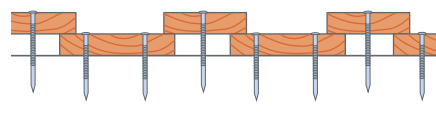

Board on board

Fixing used to install the top board must NEVER pass through the underside board.

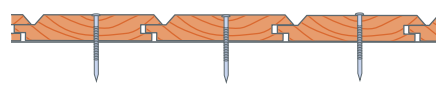

Tongue & Groove

Boards under 100mm wide only require one centrally placed fixing.

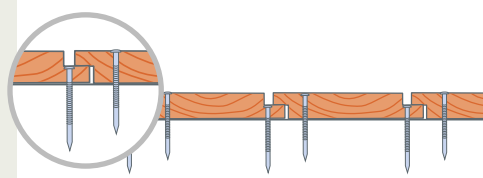

Shiplap

Boards wider than 100mm require two fixings per board at every batten.

All drawings are for illustrative purpose only and are not to scale.

These cladding arrangement drawings are generic scenarios. If more complex arrangements are required say for multi storey buildings it is advised to consult an architect or structural engineer to assure safety through design.

Typical cladding arrangements: Timber Frame (new build)

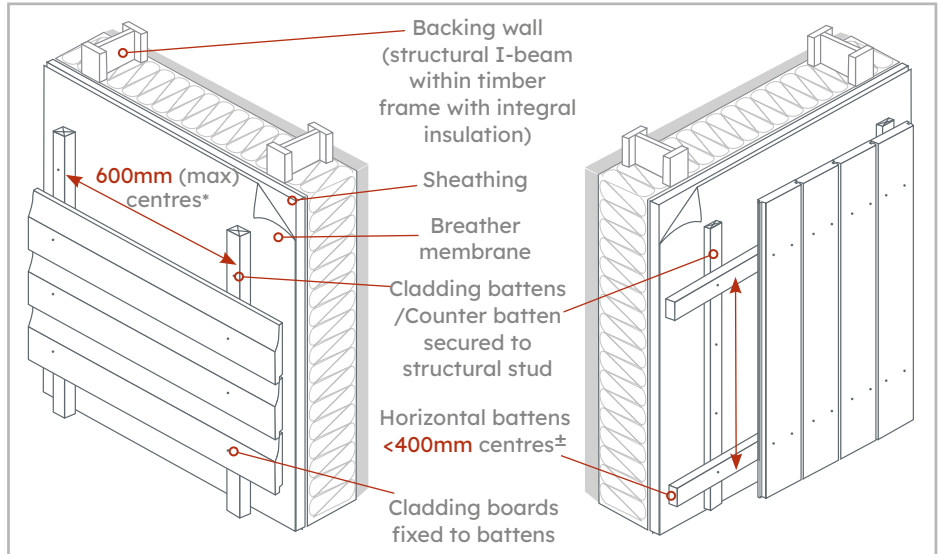

* For diagonal cladding or for boards with high moisture content (e.g. green oak) space battens at 400mm (max).

± The horizontal counter batten spacing depends on the wind load and needs to be closer together than is often assumed, anywhere between 200 - 400mm.

Masonry Buildings

If adequate insulation already exists within the walls of a masonry building, the batten supports plus cladding boards can be fitted directly to the external wall (figure 1).

Protect solid walls from water penetration by either a waterproofing coating or breather membrane. It is not usually necessary to add weather protection if the masonry wall is of cavity construction.

If additional insulation is required, cladding may be fixed to an existing solid wall property in several ways:

- Fixed to cladding battens fastened directly to rigid insulation (see note **CAVITY BARRIERS**) which is securely attached to outer wall using special fixings (figure 2);
- Fixed to cladding battens attached to secondary battens - part of double layer insulation arrangement which is securely attached to the outer wall (figure 3);

The insulation layer should be no more than 100mm thick unless the support assembly is designed to take lateral loads.

Where there is concern about additional loads being attached or the wall is uneven/out of true, the cladding may be fixed to battens attached to a self-supporting treated timber frame. Be sure to consider **thermal bridging** with regards to the insulation.

figure 1

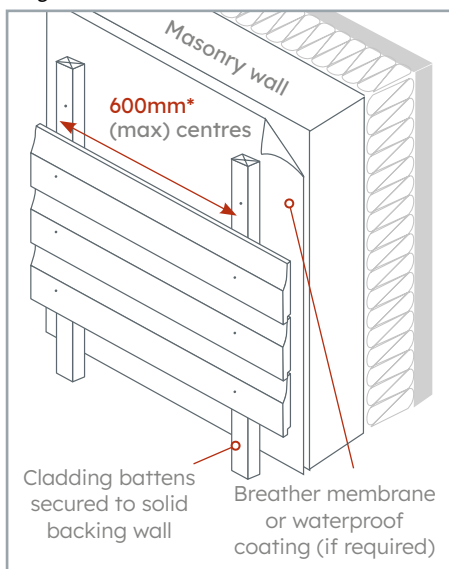

figure 2

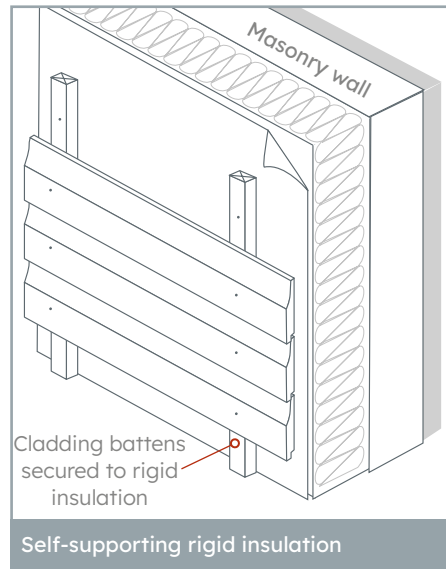
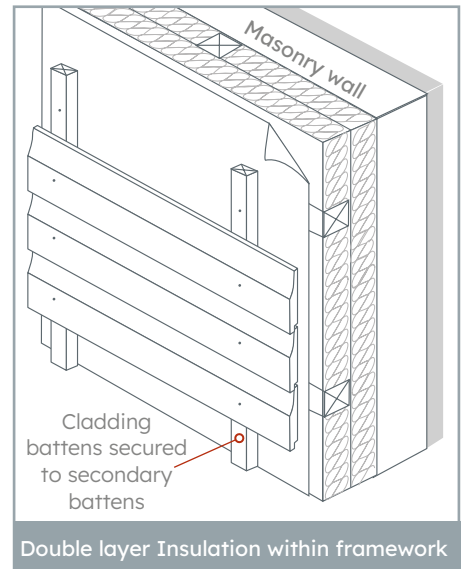
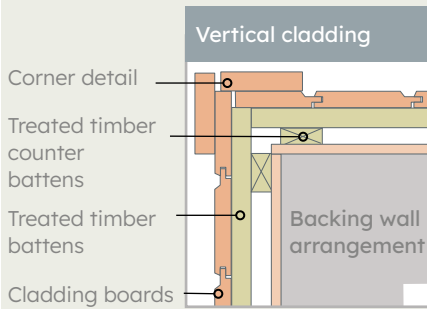

figure 3



All drawings are for illustrative purpose only and are not to scale.



Typical design detail of external and internal corners

- **Corner cover strips** are usually available in solid section or pre-formed profiles as shown in the images below.
- Leave a gap of **8 - 10mm** between the board ends and the corner finishing detail to allow for maintenance and reduce water entrapment.
- A **3mm gap** should be left between the up-stand and/or rebate of horizontal cladding to allow for any expansion of boards in the event of an increase in moisture content.

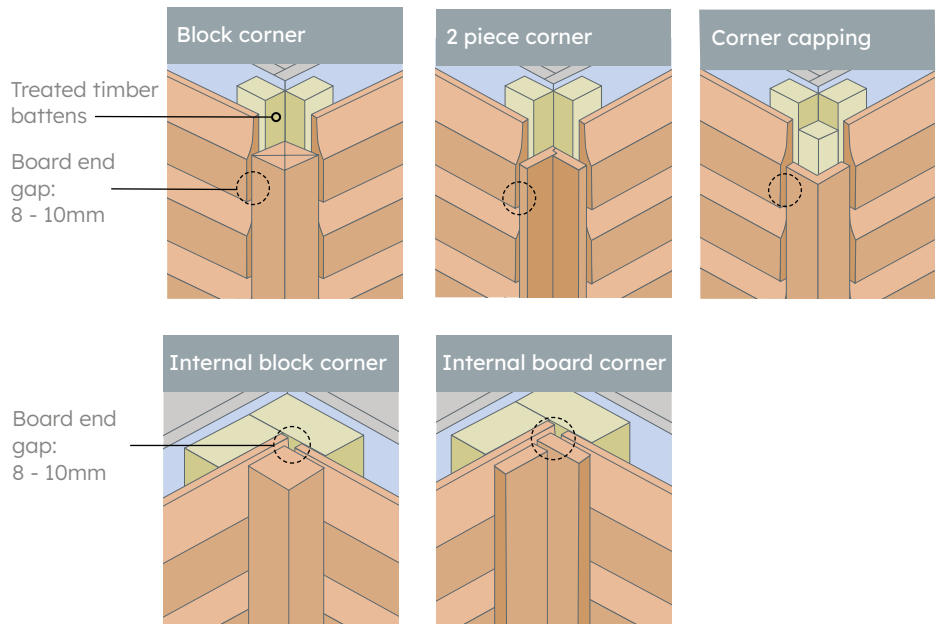

TELL ME MORE >

Refer to the 4th edition of **TRADA External Timber Cladding** manual for more detailed design guidance.

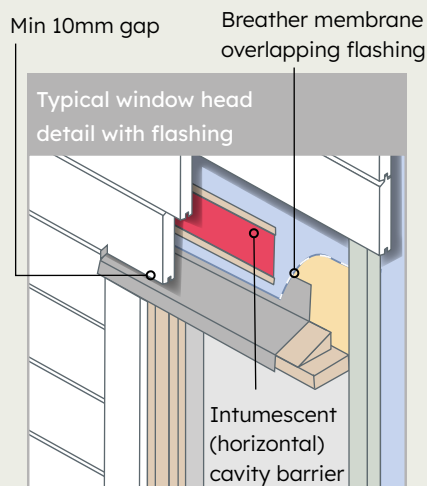

Windows and door openings

There are numerous ways of creating window and door openings within a timber clad facade – typically influenced by the design of the project.

Certain principles remain the same:

- The joint between the window casement and surrounding wall is important and needs to be both **weather tight** and **fire resistant**.
- Wherever possible there should be **rain and wind-proofing layers** separated by a well ventilated cavity.
- Consider the **dimensional relationship** between the apertures and board sizes, where the **board width or overlap** may have to be varied to accommodate the opening.
- Properly designed and installed **flashing** is essential, especially at the window sill. Consider vertical 'waterbars' at sides and rear.
- Leave **adequate gaps** where board edges meet **flashing/sills** (min 10mm).
- To ensure fire resistance, install **cavity barriers** (vertical barriers can be formed from timber battens).
- Preservative treated boards that have been cut should have an **end grain brush-on preservative** applied to ensure the integrity of treatment.





Abodo 'Vulcan' cladding, New Zealand (Glenalmond Timber).

Photo: Jason Mann

Eaves and parapets and abutments with adjacent surfaces

Normal or deep eaves shelter the top of a wall. Typical UK recommendations suggest eaves should project by **at least 50mm**.

- Where large eaves are not appropriate to a building design it is still important to protect the wall head using a **flashing**.
- Where possible the **end grain of vertical boards** should always be **protected** against moisture penetration by an overhang, a metal capping or use of an end grain sealing product.
- If cladding is left uncoated, deep eaves can lead to uneven weathering of the wall below. If this is an issue, cladding can be carried above the roof height as a **parapet***.

*For details of parapet benefits and potential issues refer to your architect / structural engineer.

Ground level cladding and abutments with roofs or decks needs particular attention:

- Metal vermin mesh is needed at the base of all cavities near the ground.
- Leave at least **200mm** between the **bottom edge of the cladding and the ground** to prevent damage from excessive moisture and discolouration due to splashing. If possible adjacent surfaces should drain falling rain and water run off e.g. gravel.

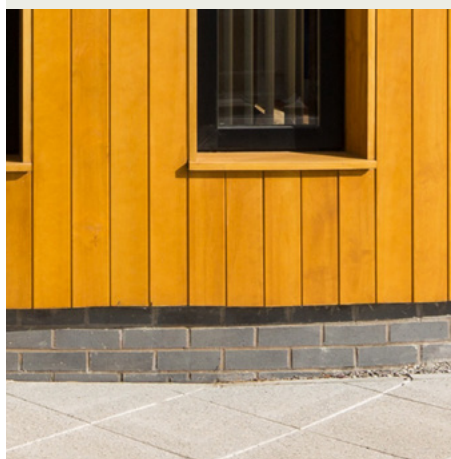

Metal Fixings

TELL ME MORE >

*NOTE: some species of timber can emit acids (*such as acetic acid*) which have corrosive effects on certain metals.

For **Western Red Cedar, Douglas Fir** and some hardwoods, only use **stainless steel or specialist coated fixings** otherwise the reaction to iron can cause permanent black spotting and corrosion staining of the surface.

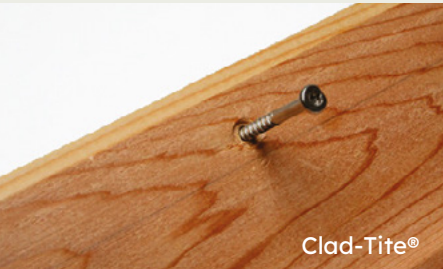

Metal Fixings

This section provides advice for connecting timber to timber only.

All metal fixings – nails, screws, concealed support systems, bolts and accessories shall be made from **corrosion resistant materials** whether the board surface is to be finished with a coating or left unfinished to weather.

Suitable metals

- **Stainless steel - Austenitic grade***
- **Silicone bronze** (*suitable for shingles /shakes ONLY*)
- **High performance coated steel**
- **Hot dipped galvanised (BS7371:6 min) copper** ✓

Unsuitable metals

- **Aluminium**
- **Electro plated steel**
- **Brass** ✗

- The use of dissimilar metals on the same fixing point should be avoided to minimise the risk of **galvanic corrosion**.
- When using **galvanised** fixings care must be taken to **prevent the coated surface being damaged** by hammers or driver bits as this can lead to corrosion of the mild steel below.

SCREWS OR NAILS FOR CLADDING FIXING?

Face fixing is the preferred method of fixing cladding boards to battens and done neatly, it should not detract from the design.

Softwood

- For most cladding softwoods, **ring shank nails** are recommended.
- Ring shank nails with **large diameter** heads are recommended to prevent head-side pull through of the connection. Fastener head should be at least twice the shank diameter unless proprietary fixings are used.

Hardwood

- On hardwoods and some higher density softwoods (ie. Siberian Larch, Douglas fir), the use of **screws** is recommended. **Ring shank nails** can be used with **Larch** providing the minimum spacing distances are maintained. An end distance of at least 200mm is required unless the hole is pre-drilled.
- For such dense species with a **potential for splitting around fixing points**, pre-drill **pilot holes** (*70% of shank diameter*).
- On **green oak**, to take up the shrinkage that will occur, it is important to use at minimum **4mm oversize pilot holes with washers** or fixings with larger heads (only use green oak if the installer has experience of the species).

APPLICATION

- **Pneumatic fixing guns should be used with care** to ensure the cladding surface is not affected by impact damage or the fixings driven below the surface. Many fixings supplied for gun application come with off centre D shaped heads and designers should satisfy themselves that this is aesthetically acceptable.
- For screw fixing, hand held **'impact' type screw drivers are best** as these are less likely to damage the wood or the drive recess and will insert the screw at optimum speed and prevent the coating burn associated with high speed power drivers.
- **All fixings should finish flush with the surface** and should not be punched or countersunk because this can result in splits and surface staining. As such it is important to ensure that the cladding moisture content is around 16% at time of installation to avoid shrinkage that would leave fixings proud of the surface.

Metal Fixings

TELL ME MORE >

Cladding assemblies need to be capable of carrying their own weight and any imposed loads (mainly, wind).

Eurocode 5 details formulae for determining the axial withdrawal strength of nail and screw connections. The table to the right references this to illustrate common fastener lengths.

For further detail, refer to the relevant structural Eurocodes:

- BS EN 1990:2002+A2:2005
- BS EN 1991-1-1
- BS EN 1991-1-4:2005+A1:2010
- BS EN 1995-1-1:2004+A2:2014

This information gives fastener recommendations for probable peak wind loads up to 1.2 or 2.5 kN/m². In the rare event that the design wind load is greater than 2.5kN/m² the cladding assembly needs to be designed by a structural engineer.

On new builds that have gone through building control, the peak wind load will have been determined by the project engineer. If that value is unobtainable, then it needs to be calculated using guidance from the 4th edition of TRADA's External Timber Cladding manual.

NAIL AND SCREW SIZING

Cladding boards to battens

The fastener diameter is limited by the need to minimize the risk of timber splitting.

Ring shank nails: recommended minimum diameter 2.3mm.

Screws: recommended minimum diameter 4 mm.

The traditional rule for determining a fastener length (L) is typically 2.5 times the cladding board thickness. However this is not strictly true. A fastener must secure the cladding board firmly in position and provide adequate penetration into the support batten – there is no advantage to the fastener penetrating the rear face of the batten.

There are 3 things to consider, not excluding particular features of brand types (refer to manufacturer's guidelines) and **Eurocode 5** details the following:

- Board(s) THICKNESS (T)
If using 2 overlapping boards simply add values of thicknesses together.
- PENETRATION of threaded part of fastener (PEN) into the batten:
minimum 19mm
- Nominal length of fastener POINT (LP) :
5mm for nails and 10mm for screws

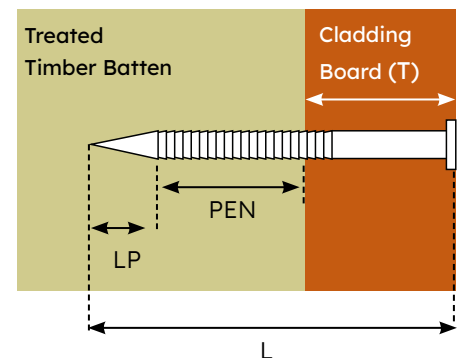

$$\text{LENGTH OF FASTENER (L)} = T + \text{PEN} + \text{LP}$$

This fastener length guidance can be summarised as:

for NAILS = total board thickness + 24 mm

for SCREWS = total board thickness + 29 mm

Fixing battens to counter battens

Where it is necessary to fix cladding battens to counter battens use nails or screws as shown in the table below. Horizontal batten spacing is wind load dependent, pay attention to the closer spacing required.

Table 4. Fastener sizes for connecting horizontal battens to vertical counter battens

Design wind load (kN/m ²)	NAILS			SCREWS		
	Diameter (mm)	Length (mm)	Batten centres (mm)	Diameter (mm)	Length (mm)	Batten centres (mm)
Below 1.5	3.0 to 3.8	75 to 120	200	6	110 to 180	400
1.5 to 2.5	-	-	-	6	110 to 180	300

Fixing battens to the backing wall

All too often more attention is given to how the cladding is attached to the battens when in fact attaching the battens to the wall is more critical since these are exposed to the full wind load whilst wind loads on the cladding layer are generally far lower.

There are several aspects to consider - the backing wall type, any additional insulation included as part of the batten assembly, if counter battens are being used and the wind loads to be placed on the building. The following tables illustrate the two most common cladding application scenarios but for other configurations please refer to the 4th edition of TRADA's External Timber Cladding manual.

Metal Fixings

The following tables gives guidance for timber cladding assemblies carried on a timber-framed or mass timber backing wall. If the backing wall is masonry, connections between the cladding support battens and backing wall need to be designed by a structural engineer.

Table 5. Fastener sizes for connecting vertical battens or counter battens to the backing wall (for horizontal boards or vertical boards with flat rear face)

Design wind load (kN/m ²)	NAILS			SCREWS		
	Diameter (mm)	Length (mm)	Maximum Batten centres (mm)	Diameter (mm)	Length (mm)	Maximum Batten centres (mm)
Below 1.5	2.8 to 3.8	75 to 120	150	5	90 to 120	200
1.5 to 2.5	3.4 to 3.8	90 to 120	150	5	90 to 120	150

Table 6. Fastener sizes for connecting horizontal battens to the backing wall (for vertical board-on-board timber cladding)

Design wind load (kN/m ²)	NAILS			SCREWS		
	Diameter (mm)	Length (mm)	Maximum Batten centres (mm)	Diameter (mm)	Length (mm)	Maximum Batten centres (mm)
All wind loads below 2.5	3.8	100 to 120	600	5	90 to 120	600

Double batten arrangement for abutting boards

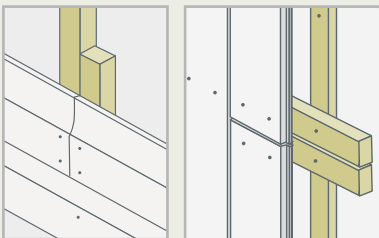

Connecting double battens

Where cladding boards abut, a double batten arrangement is recommended to avoid the risk of splitting; an additional short length batten can be fixed alongside an existing batten. Assuming that the batten sizes are as specified on page 28:

- the nail diameter for connecting the short batten should be 2.8 to 3.8 mm;
- with a length of 75 to 100 mm.
- The additional batten needs to be about 100mm longer than the width of the board being butt jointed.

MAINTENANCE

If **power washing**, take care not to cause damage to the cladding by adjusting the power to low and not positioning the lance too close the timber's surface. Once cleaned the surface will benefit from a topical coating with a penetrating water repellent coating.

Images courtesy of Owatrol.



General good practice

- **Periodic inspections** should be carried out to check that the cladding system continues to perform as required and to identify if any repair work is needed. Maintenance requirements will vary according to whether the cladding is finished with a coating or uncoated. Uncoated systems generally require little maintenance and can be left to weather naturally.
- If you wish to **refresh the visual appearance** of cladding, you have a range of options depending on the extent of surface changes to be remedied. For moderate changes in appearance, **proprietary surface cleaners** can give good results. Manufacturer's guidance should be followed. Research by BM TRADA identified **power or jet washing** to be effective and more economical for large areas of cladding.



- **Biological staining** (green algal growth or grey/black fungal staining typically) can be removed by washing the surface with a **1:4 dilution of household bleach and water**.
- If, at a later stage, you decide to **apply a coating to well weathered, bleached wood**, you will have to remove the degraded surface layer which involves a lot of preparatory work.

Any surface coatings applied require maintenance and the coating manufacturer's guidance should be followed. It is far better and less hassle to maintain coatings on a proactive basis, rather than allow them to deteriorate before acting.

General requirements for maintenance coats* to cladding		
COATING TYPE	RE-COAT FREQUENCY	RE-COAT PREPARATION
LOW build stain	HIGH e.g. every 2 years	Surface cleaning
MEDIUM build stain	MODERATE e.g. every 3 to 4 years	Light sanding
HIGH build paint	LOW e.g. every 5 years	Heavy sanding

* This table only applies to **organic coatings**. Low build **inorganic coatings** are available that have a similar service life to high build paint.

The durability of the enhanced 'reaction to fire' properties which **flame retardant treatment** imparts to timber is classified according to **BS EN16755** 'Durability of reaction to fire performance'.

- **Uncoated** cladding treated with **flame retardant**, rated as **EXT grade** under BS EN 16755, has an anticipated service life of **approximately 25 years**.
- Cladding treated with an **INT2 flame retardant treatment type** which is subsequently **coated** has a similar anticipated service life **provided the coating is regularly maintained in line with the manufacturers recommendations**.

UK BUILDING REGULATIONS & COMPLIANCE

TELL ME MORE >

Procuring Sustainable Timber

To learn more about this issue **Wood Campus** have developed a free on-line training module.

Watch it here: www.woodcampus



FR Timber Products and CPR

For further guidance on accurate specification, effective chain of custody and CPR compliance, please see **Guidance Notes WPA FR 4, 6 & 8**. Download them here:

www.thewpa.org.uk/resource-centre

An **approved body** is an organisation approved by the UK government (a **notified body** in the EU) to assess the conformity of certain products before being placed on the market.

Sourcing Timber

The UK timber industry has a great responsibility in advocating timber as a legal, sustainable and renewable resource. This encompasses the purchasing and selling of 'certified' timber products – supporting responsible sourcing and good forest management.

Certification is a process that results in a written statement (certificate) stating the origin of the wood and its status, following validation by an independent third party. Certification allows buyers to identify products made with timber from legal and sustainably managed forests. Certification also allows merchants to better manage risk in their supply chains.

Certification of forest management includes inventory, management planning, silviculture, harvesting, road construction etc., as well as the environmental, economic and social impacts of forest activities. It takes place in the country of origin

Chain of Custody certification covers the supply chain of domestic and export markets.

The UK Government recognises two certification schemes as equal: the **Forest Stewardship Council (FSC)** and **Programme for the Endorsement of Forest Certification (PEFC)**.

Always purchase accredited material from sources who can verify the legality of the product. If in doubt, ask to see certification.

Responsible Purchasing and TDUK members

Timber Development UK (TDUK) has developed a **Responsible Purchasing Policy (RPP)** which is a risk management framework in line with the requirements of the **EU/UK Timber Regulation (EUTR)**. Adhering to the policy is a mandatory aspect of TDUK membership. Each business member submits itself to annual independent scrutiny to ensure that all non-certified products can be verified as coming from legal sources. The RPP framework has also been adapted for higher risk products and countries to allow for an auditing process to confirm compliance with other regulatory requirements such as the **Construction Products Regulation (CPR)**.

CE / UKCA marking

The CE mark confirms the compliance of a product with all applicable European health, safety, performance and environmental requirements.

Due to Brexit, CE marking of goods being placed on the market in Great Britain is gradually being replaced by UKCA marking.

- Under the Construction Products Regulation (CPR) those who manufacture timber cladding have a legal obligation to draw up documentation, referred to as a **Declaration of Performance (DoP)**, and apply either a **CE (EU)** or **UKCA (GB)** mark (physically or documented) when the product is first placed on the market .
- The standard that applies to cladding is **BS EN 14915:2013+A2:2020 Solid wood panelling and cladding: characteristics, requirements and marking**.
- If anything is added to the timber cladding that might change any of the characteristics in the DoP (such as subsequently treated with a **flame retardant – FR**), then the DoP must be updated.
- Fire protection is **safety critical**. Flame retardant treatment documentation must be underpinned by **Factory Production Controls** which are audited and accredited by either an **approved body** (GB) or **notified body** (EU).
- A DoP must be made readily available to the purchaser(s) digitally or in hard copy.

Fire Risk

All information given here is correct at time of publication. Such regulation may be subject to change - always refer to the current national Building Regulations.

External Timber Cladding and Fire Risk

In the wake of the Grenfell fire tragedy, the UK government has conducted a series of consultations into the use of different cladding materials on high rise buildings. The results of the latest of these, published in June 2022, confirm that timber, **where necessary enhanced with flame retardant**, continues to be approved as a suitable material for external cladding and balconies on residential buildings, under Building Regulations, for **BUILDINGS BELOW 11 METRES** in England, Wales and Scotland.

TDUK, WPA and TDCA recommendations

These three industry bodies strongly advocate that an **independent, professional fire risk assessment** that considers building design, use, materials and location is **essential at the design stage for multi-occupancy and assembly buildings**, such as community centres and schools, **regardless of height**.

Furthermore, in multi-occupancy and assembly buildings, timber-based cladding and balcony components should be **treated using a quality assured factory-applied flame retardant to Euroclass B** performance levels – the highest **reaction to fire** standard achievable for an organic substrate – **unless shown NOT to be necessary by an appropriate risk assessment process**. † See WPA Guidance Notes for further details.

This principle of risk assessment is embodied in the Construction Design and Management Regulations and is reinforced by the Ministry of Housing, Communities & Local Government.

TELL ME MORE >

[Euroclasses and Fire Terminology](#)

For further guidance please see WPA Guidance Notes **WPA FR 1, 2 & 3**.

www.thewpa.org.uk/resource-centre



Building Regulations requirement in England

The requirement for treatment with a flame retardant depends on the **building type**, **boundary distances** and the **size of the cladding area** being considered (see diagram on page 40). Timber can be pressure pre-treated with a flame retardant to enhance its reaction to fire properties to varying degrees. The substrate properties are then categorised using the **Euroclass** system.

External surface cladding on buildings in **all residential purpose groups**, including those classed as **RELEVANT** (see definition on page 40) where there is a storey **at least 11m above the ground** must be Euroclass **Class A1** or **A2**.

For a material to be classed as **non-combustible** or of limited combustibility it must achieve Class A1 or A2 in testing.

Whilst it is not possible to enhance any organic substrate, including wood, to a Euroclass A rating, flame retardant treatments enhance safety, add value and continue to enable timber cladding to be fit for purpose for many low rise, domestic housing or non-residential applications in compliance with Building Regulations. Untreated wood-based materials normally have a Euroclass E or D rating and this can be enhanced to Euroclass B or C by the industrial application of a flame retardant formulation.

Fire Risk

TELL ME MORE >

'June 2022 amendments to Approved Document B, volume 1 and volume 2' in addition to 'Fire Safety: Approved Document B' detail the latest building regulation standards covering fire safety matters.

For further information visit: www.gov.uk

Fire Safety: Approved Document B details the definitions of building uses and information regarding *unprotected areas where the building is more than 1m from a boundary.

Euroclass (EN 13501-1) reaction to fire performance criteria also includes classification categories for smoke production (class s1 to s3) and creation of flaming droplets (class d0 to d2).

Definition of 'Relevant' building (ref. Approved Document B)

A building with **a storey** (not including roof-top plant areas or any storey consisting exclusively of plant rooms) **at least 18m above ground level** and which:

- i) contains one or more dwellings;
- ii) contains an institution; or
- iii) contains a room for residential purposes.

RELEVANT buildings are now defined as: residential flats/rooms, hospitals, care homes, sheltered housing, dormitories in boarding schools, student accommodation, hotels, hostels and boarding houses

Non-combustible external cladding is now mandatory for this category and is generally considered as a sensible design precaution in the wake of Grenfell. The requirement for non-combustible materials also applies to **structural timbers** within the external wall frame of relevant buildings but does not apply to doors, door frames and window frames. For such buildings, the new performance requirements apply to all **faces**, above and below 18 metres, right down to ground level.

Regulations (*England and Wales*) for **MINIMUM Euroclass performance requirements for timber cladding applied to buildings** (*further rules apply around 'unprotected areas' - see current building regulations).

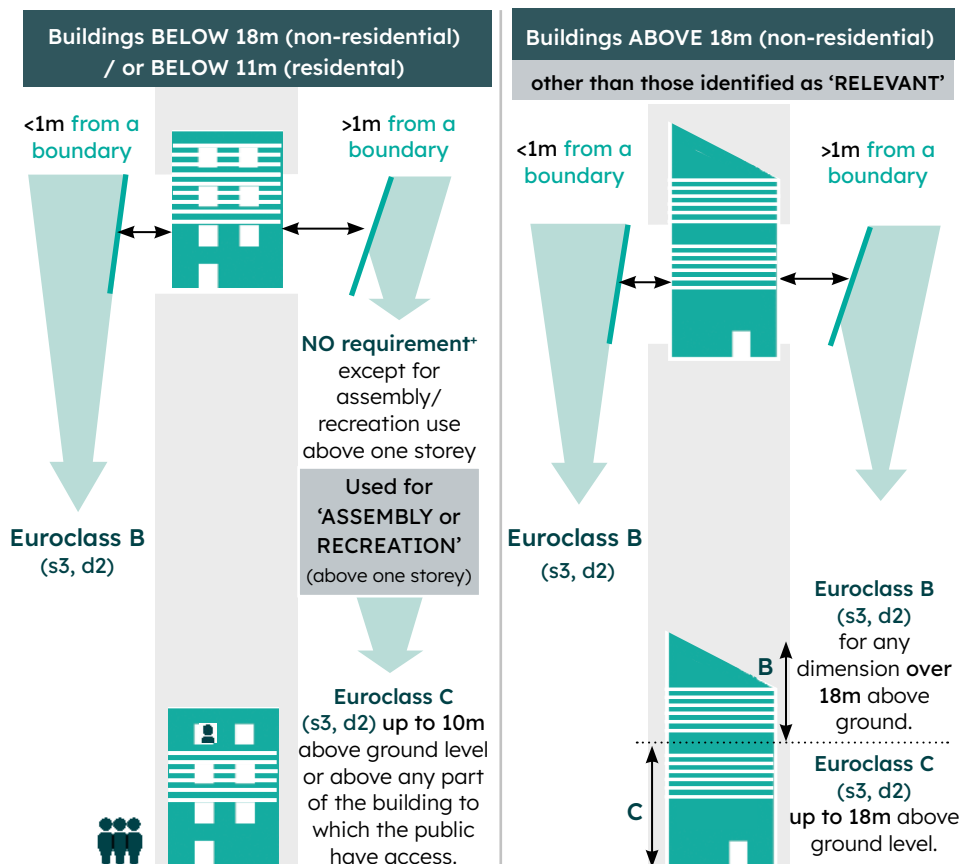

SUMMARY OF CHANGES

For 'RELEVANT' (and residential multi-storey) Buildings

- **No timber cladding on buildings over 11m**, but you can use timber within the external wall structure **up to 18m**.
- **No timber in external walls on buildings above 18m** - this affects external wall framing/CLT and cladding.

Fire Risk

Building regulations in Scotland

External wall cladding and balconies not more than 1m from a boundary should be rated Euroclass A1 or A2. Where the building is more than 1m from the boundary these should be constructed from materials with a reaction to fire rating in accordance with the following table (+ further rules apply around unprotected areas - see current national building regulations). Testing to BS 8414 can be used as an alternative to these provisions:

TELL ME MORE >

+ For detailed information on current building regulations in Scotland visit: www.gov.scot

BUILDING USE	TOPMOST STOREY HEIGHT ABOVE GROUND	EUROCLASS REQUIREMENTS*
Entertainment and Assembly Building	Any	A1 or A2
Entertainment and Assembly Building with a total storey area not more than 500 m ²	11m	B - E (see regulations)
Hospital and residential care building	Any	A1 or A2
Hospital and residential care building with a total storey area not exceeding 200 m ²	11m	B - E (see regulations)
Any other building (including domestic)	More than 11m	A1 or A2
	Not more than 11m	B - E (see regulations)



CHECKLISTS

TDUK, WPA and TDCA recommendations around fire risk

For multi-occupancy and public assembly buildings, conduct an independent, professional fire risk assessment at the design stage, regardless of height.

If fire protection is required, timber-based cladding and balcony components should be treated using a quality assured factory-applied flame retardant to Euroclass B performance levels – the highest ‘resistance to fire’ standard achievable for an organic substrate.

Key points for specifiers, buyers and installers

MATERIAL CHOICE

The timber you choose for your cladding needs to be durable enough to meet the design service life required in what is an exterior, above ground environment.

Wood weathers with external exposure, consider this when selecting your timber type and if you choose a coating or finishing product be aware of maintenance requirements.

Timber battens should be capable of providing at least the same service life as the cladding boards and should be capable of taking fixings without splitting.

DESIGN

Make sure the design and installation will accommodate the natural seasonal movement of the timber by paying attention to correct movement gaps and/or overlaps for the profile and species used.

Pay particular attention at window and door openings, consider the dimensional relationship between the apertures and board sizes.

A drained and ventilated cavity (open at the top and bottom) situated behind the cladding, channels any moisture back to the building’s exterior.

INSTALLATION

When storing timber, to preserve the high quality it should be protected from precipitation, sun, dirt and ground moisture prior to installation.

Timber should be supplied/used with a moisture content of $16\% \pm 4\%$ (unless using green oak – specialist knowledge required).

Only use fixing types which are suitable for the wood species used and for exterior use, ensure they are made of corrosion resistant materials.

For through the face fixing, place two fixings at quarter points of the board (unless board is <100mm wide – one fixing is adequate) and a minimum of 20mm in from board ends.

If you crosscut any pressure treated timber on site, coat the cut ends with brush-on end grain wood preservative to maintain the integrity of the treatment.

Fit insect and vermin mesh to all appropriate openings to prevent access by large insects and small mammals respectively, into the cavities.

Minimise the risk of flame spread within cavities, with the use of cavity barriers.

MAINTENANCE

Periodic inspections should be carried out to check that the cladding system continues to perform as required and to identify if any repair work is needed.

Any surface coatings applied require maintenance and the coating manufacturer’s guidance should be followed. It is far better and less hassle to maintain coatings on a proactive basis, rather than allow them to deteriorate before acting.

COMPLIANCE

Always purchase accredited material from responsible sources who can verify the legality of the product. If in doubt, ask to see certification.

Be sure any CE/ UKCA marked product also carries a Declaration of Performance (DoP) and ensure it meets your original requirements.

Adhere to Building Regulations concerning the use of Flame Retardant timbers, particularly in multi-occupancy, multi-storey buildings.

ALWAYS KEEP ALL RECORDS SAFE AND ACCESSIBLE.

SOURCES OF INFORMATION

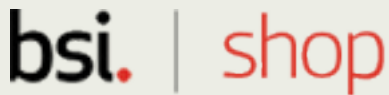

The Standards shown here can be purchased and downloaded from the British Standards Institution online facility: shop.bsigroup.com

Free to download on the WPA website: www.thewpa.org.uk/resource-centre



British Standards relating to cladding specification

BS EN 350	(2016) Durability of wood and wood-based products. Testing and classification of the durability to biological agents of wood and wood-based materials.
BS EN 335	Durability of wood and wood based products. Use classes: definitions, application to solid wood and wood-based products. Classifies timber applications into five 'Use Classes' depending on the risk a component faces from a biological hazard i.e. decay, disfigurement by surface moulds or insect attack during service. External timber cladding is a Use Class 3 application. This means it is considered to have a medium risk of attack from such biological organisms. However, poor detailing, installation or maintenance may result in cladding being exposed to more severe conditions so it is good practice to choose timber that has a more than adequate durability to meet the service conditions.
BS EN 942	Timber in joinery. General requirements. Specifies the general requirements including in particular the grading and classification by appearance quality of timber in joinery products or individual joinery parts.
BS EN 1310	Round and sawn timber. Method of measurement of features.
BS 8417	Preservation of wood. Code of practice
BS 8605	External Timber Cladding Part 1: Method of specifying. Covers aspects that can be controlled by the manufacturer and it provides useful information for those specifying and using timber cladding. A Part 2, which will deal with installation best practice, is currently being written.
BS EN 14915	Solid wood panelling and cladding – Characteristics, requirements and marking. This standard describes the data set required for CE marking and labelling to comply with EU Construction Product Regulations

Technical publications

External Timber Cladding (4th edition 2021) - TRADA

TRADA provide many technical publications but the large format, illustrated manual **External Timber Cladding** is a definitive industry guide to the specification, design and installation of timber cladding in the UK.

Code of Practice: Industrial Wood Preservation – Wood Protection Association

A valuable and current reference of standards and good practice for treaters, specifiers and users of treated wood.

Guidance Notes : Flame Retardant and Preservative treatments - WPA / TDUK

As part of a joint collaboration, The Wood Protection Association and Timber Development UK (formerly Timber Trade Federation) have produced a series of resources aimed at educating the treated timber supply chain and the wider specification market. Every aspect of timber treatment is covered in concise 2-page format documents.

Wood campus

Visit www.woodcampus

You can go through the courses without registering – completing in one go or dipping in and out.

If you've completed a course and passed the assessment, your email will be requested so that you can download your CPD certificate.



Visit www.tdca.org.uk

Free on-line training courses

Focus on Cladding: CPD Accredited Course - Wood Campus

In partnership with the TDCA, the course is accredited by RIBA (the Royal Institute of British Architects) and covers all the important issues you need to be familiar with if you are specifying timber cladding, from sustainability to fixings and detailing. It features case studies and advice from award winning architects.

Fire Safety and FR-Rated Timber: CPD Accredited Course - Wood Campus

Working in partnership with LABC, the Wood Protection Association has developed this on-line course to help Building Control Officers improve their understanding of how wood behaves in a fire. It covers how to enhance wood's performance to comply with Building Regulations and other regulatory requirements and so ultimately to build safer buildings. This course is equally applicable to all involved in the specification, use and regulation of flame retardant treated wood products.

Design inspiration

There's a wealth of timber cladding inspiration and reference featured in the [Case Studies](#) and [Gallery](#) pages of the The Timber Decking & Cladding Association (TDCA) website. In addition, Timber Development UK (TDUK) showcase a number of projects under their [TimberWorks](#) banner.

Find an accredited supplier or installer

TDCA administer the [CladMark](#) Quality Assurance Schemes for timber cladding suppliers, products and installers. Based on existing quality assurance standards (ISO 9000, EN45011/12, ISO Guide 62/65) the Schemes help all those engaged in the specification, design, installation or purchasing of cladding to ensure that the products they buy, or the TDCA registered contractor they commission, will be of the highest quality.

To ensure standards of performance are maintained, the accreditation of an individual firm is audited and renewed every 12 months by an independent inspector appointed by the TDCA.

You can quickly and easily source your nearest supplier of timber cladding and associated products and services with the on-line [Supplier Database](#) and you can filter your search to find exactly what you're looking for.

Dispute resolution, inspection and expert witness services

Helping to resolve difficulties with timber cladding projects, the TDCA offer a number of expert services to private home owners, architects, surveyors, structural engineers and many other organisations. The bespoke commissioned work might include:

- General condition surveys and maintenance reviews
- Assessing material faults and possible causes on site
- Advising on correct material specification and good practice standards

GLOSSARY OF TERMS

Batten	Parallel strips of timber fixed to a wall to provide a framework for attaching cladding boards or panels.
Board on board	Vertical overlapping rectangular cladding board arrangement creating a closed joint and uneven rear face.
Cavity	By using a series of timber battens, a cavity between the cladding and the backing wall structure can be created. Open at top and bottom a cavity allows through ventilation and channels any moisture that might enter, back to the building's exterior.
Cavity Barrier	Inhibits fire spread within a cavity. Performance is expressed in terms of time.
Chamfer	To remove top or bottom edges lengthwise at an angle.
Combustible	(see Non-combustible)
Counter Batten	Additional vertical batten fixed beneath a horizontal batten to create extra cavity space.
Countersink	To cut a recess that allows the head of a screw to lie flush with a surface.
CPR	Construction Products Regulation. The CPR aims to ensure the reliability of information on the performance of construction products. It places obligations on manufacturers, distributors and importers of construction products when these products are placed on the market.
Cup	To bend as a result of shrinkage, specifically across the width of a piece of wood.
Density	The mass of a unit volume of wood at a specified moisture content. Density is an excellent indicator of wood strength; the higher the density the stronger the wood.
Desired Service Life	(DSL) The number of years a timber component should last, usually conferred by preservative timber treatment .
Distortion	The change in the shape of a piece of timber or timber-based material brought about by shrinkage as the timber dries. It includes bowing, twisting and cupping.
DoP	Declaration of Performance is a key part of the Construction Products Regulation (CPR). It provides information on the performance of a product. Each construction product covered by a European harmonised standard or for which a European Technical Assessment has been issued needs this Declaration and has to be CE marked (gradually being replaced with the UKCA mark).
Durability	Resistance to decay or insect attack. Durability can be either a natural characteristic of a particular species or it can be conferred on a species by preservative pre-treatment or a wood modification process. The degree of timber's natural durability varies from species to species.
Eaves	The edges of a roof that project beyond the walls.
End grain	The exposed face of timber produced when it's cut through a plane that's perpendicular to the grain.
Face fixing	To affix the cladding board with a screw or nail, through the front face of the board

Featheredge	A traditional cladding profile design which is shaped like a long thin wedge - it is fitted horizontally by overlapping.
Flame Retardant	Treatments that enhance the 'reaction to fire' properties of wood and wood - based materials. Generally work by reducing ignitability and the surface spread of flame, heat and smoke release, providing vital extra time for a safe escape.
Hardwood	Wood of trees of the botanical group 'dicotyledons'. Grown in both temperate and tropical climates. The term 'hardwood' is historical and does not imply that timber from these species is necessarily harder than from a softwood species, nor should it be assumed that all hardwood species have a high natural durability. As with all wood species consideration must be given to the legality and sustainability of the wood products.
Heartwood	Inner zone of a tree trunk that, when the tree was alive, provided structural support but no longer contained living cells. The heartwood may be darker in colour than the outer sapwood though not all species show a clear difference between the two. The heartwood is often more durable than sapwood.
Impregnation	A method of application associated with industrial timber treatments whereby the formulation is forced under pressure into the timber cells.
Intumescent	When exposed to high heat, intumescent strips used as cavity barriers, are triggered to expand, closing any gaps to stop fire spreading for a period of time.
Jamb	The vertical side member of a door or window frame.
Mitre	Two pieces forming an angle, or a joint formed between two pieces of wood by cutting bevels of equal angles at the ends of each piece.
Modification	A term used to describe solid timber (predominantly softwood, occasionally hardwood) that has undergone a chemical, biological or physical process. This essentially creates a new timber product with enhanced performance properties - principally the improvement of durability.
Moisture content	Mass of moisture in wood expressed as a percentage of its oven-dry mass.
Movement	The swelling and shrinkage of wood as a result of changing moisture content. Movement in length is always negligible. Movement parallel with the growth rings is greater than at right angles to them. The degree of movement varies between species.
Non-combustible	For a material to be classed as Non-combustible it must achieve Euroclass A1 or A2 in reaction to fire testing. Any material rated Class B or lower is therefore classed as Combustible, albeit to varying degrees
Open jointed	Cladding components that are separated from each other by an open joint.
OSB	Oriented strand board. An engineered wood product where slivers of wood are glued together to form a flat product..
Particle board	Woodchips, sawdust, wood residues and so on that are bound or glued together to form a flat board.



Permeability	The ease with which liquids - such as preservatives or flame retardants - can be impregnated into timber. Permeability varies with species, although the sapwood of all species is more permeable than the heartwood. Permeability ratings relate to the heartwood of the species.
Preservative	An industrially applied timber treatment product which confers added durability .
Profile	Particular shape of a cladding board.
Reaction to Fire	The measurement of how a material will contribute to the fire development and spread, particularly in the very early stages of a fire when evacuation is crucial.
Fire Resistance	The measurement of the ability of a building/construction element to resist, and ideally prevent, the passage of fire from one distinct area/building compartment to another.
Sapwood	Outer zone of a tree that when the tree was alive, contained living cells. It provides a source of food for many species of fungi and insects and is always vulnerable to attack.
Softwood	Wood, whether soft or not, from trees of the order 'Gymnospermae' (see Hardwood definition). Most commercial timbers of this group belong to the botanical class 'Coniferae' (conifers).
Use Class	The British Standard for wood preservation - BS 8417, recommends that the loading and penetration of preservative, impregnated into wood, is tailored to the desired end use. So it groups the applications for treated wood into Use Classes.



**TIMBER
DEVELOPMENT
UK**

Timber Development UK

The Building Centre, 26 Store Street, London WC1E 7BT

Tel: 0203 198 9606 | info@timberdevelopment.uk | www.timberdevelopment.uk